

adbri MASONRY
working together

A close-up photograph of a corner joint in a masonry wall. The image shows several grey concrete blocks with a dark grey mortar joint. Two thick, rusty steel rebar rods are embedded in the wall, extending diagonally across the corner. The rebar is secured with wire ties. The background shows a rough, green-painted concrete surface.

REINFORCED BESSER® BLOCK
RETAINING WALLS

CONTENTS

Preface	02
Introduction	02
1.0 Retaining walls	03
1.1 Designs for reinforced retaining wall types	03
1.2 Loading Conditions	04
1.2.1 Retaining Walls	04
1.3 Material Specifications	04
1.4 Soil Classification	04
1.5 Wall Foundation	04
1.6 Infill Soil and Retained Soil	04
1.7 Drainage Systems	05
1.8 Water Penetration	05
1.9 Exploded View of Construction	05
1.10 How to Build the Wall	06
1.10.1 Preliminary	06
1.10.2 Base	06
1.10.3 Block Laying	06
1.10.4 Grouting	06
1.11 Tanking	06
1.12 Infill Soil and Drainage	06
1.13 Design Details for Wall Type 1	07
1.13.1 Level Surface Wall Layout	07
1.13.2 Sloping Surface up to 1 in 4 Wall Layout	08
1.13.3 Base and Key Sizes	09
1.13.4 Reinforcement Details	09
1.14 Design Details for Wall Type 2	10
1.14.1 Level Surface Wall Layout	10
1.14.2 Sloping Surface up to 1 in 4 Wall Layout	11
1.14.3 Base and Key Sizes	12
1.14.4 Reinforcement Details	12
2.0 Basement Walls	13
2.1 General	13
2.2 Drainage	13
2.3 Tanking	13
2.4 How to build the wall	13
2.5 Designs for reinforced basement wall types	13
2.6 Block basement wall design details for supporting a concrete floor	14
2.7 Block basement wall design details for supporting a timber floor	14
2.8 Basement walls	15
Glossary	15

PREFACE

The designs shown in the brochure are based on limit state design in accordance with the provisions of AS4678-2002 Earth retaining structures standard. The designs are hereby certified by Adbri Masonry Building Products Pty Ltd ABN 31 009 687 521.

The design details provided in this brochure have been prepared by Adbri Masonry specifically for Adbri Masonry blocks and are applicable only to retaining walls using Adbri Masonry products for residential or light commercial applications up to 3.0m high. For higher and/or more complex applications it is recommended reference be made to the Concrete Masonry Association of Australia document Reinforced Concrete Masonry Cantilever Retaining Walls – Design and Construction Guide RW01.

All designs in this brochure have been checked and approved by Arlene Nardone, CPEng RPEQ RBPV. It is the responsibility of the customer to ensure that all assumed geotechnical and loading parameters (refer page 4) are attained on site, and that all retaining walls are installed as per requirements of designs and cross sectional details.

Adbri Masonry accepts no liability for any walls outside the scope of the designs included in this brochure, or for installation of the products contained therein.

INTRODUCTION

Reinforced Besser® Block Retaining and Basement Walls consist of a reinforced concrete base which anchors the wall against overturning and sliding, and a stem of Besser® Blocks.

The stem is reinforced with steel bars placed vertically and horizontally, and all cores in the blocks are filled with semi-fluid concrete, known as 'grout'. The vertical reinforcing bars in the cores are lapped with shorter 'starter bars' embedded firmly in the reinforced concrete base. These short bars allow easier block laying, and the longer bars are put in after all blocks are laid and before grouting. The length of the lap is critically important and must be shown on the drawings.

1.0 RETAINING WALLS

1.1 Designs for Reinforced Retaining Wall Types

Retaining walls up to 3.0m high.

Wall Type 1

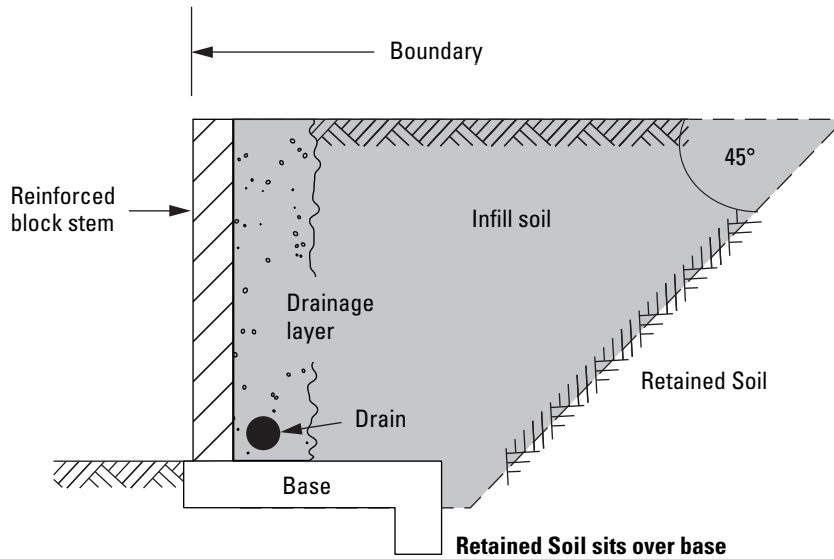

Wall Type 2

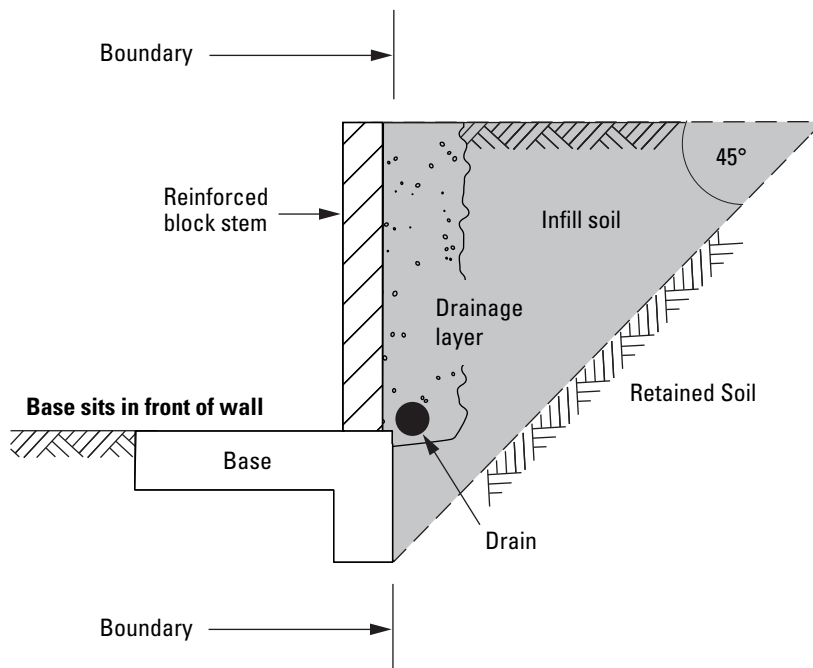

Note: Diagrams not to scale

1.2 Loading Conditions

1.2.1 Retaining Walls

These tables cover four loading conditions:

- Level surface with 2.5 kPa surcharge for walls up to 1.5m high.
- Level surface with 5.0 kPa surcharge for walls over 1.5m high.
- Sloping surface up to 1:4 with 2.5 kPa surcharge for walls up to 1.5m high.
- Sloping surface up to 1:4 with 5.0 kPa surcharge for walls over 1.5m high.

Notes:

- 300mm of soil or a private driveway imposes a load of approximately 5 kPa.
- Sloping surface steeper than 1:4 is not included in this brochure.

1.3 Material Specifications

In calculating these tables, the following material specifications were adopted:

Besser® Block

$f'_{uc} = 15$ MPa in accordance with AS 4455 - 2008

Mortar Class M3

Cement 1 : Lime 1 : Sand 6
OR Cement 1 : Lime 0 : Sand 5
plus cellulose-based water thickener

Concrete base

$f'c = 25$ MPa

Reinforcement

Yield Strength = 500MPa

Grout

$f'c = 20$ MPa with a pourable consistency and a cement content no less than 300 kg/m³

Where possible, use ready-mixed grout and specify when ordering that it is for filling blockwork. If the grout is mixed on site, use the following proportion:

Cement	1 part
Hydrated Lime	Up to 1/10th part
Mortar Sand	3 parts
10mm aggregate	Up to 2 parts

Notes:

- Maximum 10mm aggregate
- Grout should be mixed in a tilting drum paddle mixer and should flow freely without separation of the aggregate.

1.4 Soil Classification

1.4 Soil Classification

To simplify the following design tables only one type of soil has been used throughout for both infill soil and retained soil. It is classified as an average soil and would be typical of a wide range of insitu soils and would normally include; stiff sandy clays, gravelly clays, compact clayey sand and sandy silts.

The characteristic soil property has been reduced by the uncertainty factors below and upon which the designs have been based:

Uncertainty factor for drained cohesion, = $\Phi_{uc} = 0.70$

Uncertainty factor for drained internal friction angle, $\Phi_{u\phi} = 0.85$

ie: $\phi^* = \tan^{-1} (\Phi_{u\phi} (\tan \phi))$

Characteristics soil parameters	
Internal friction angle ϕ' (degrees)	Cohesion c' (kPa)
27	3

Design soil parameters	
Internal friction angle ϕ^* (degrees)	Cohesion c^* (kPa)
23	2

1.5 Wall foundation

The tables have been based on a foundation soil as described above and which must be excavated to sufficient depth to expose undisturbed material which is firm and dry.

Should a designer wish to analyse a retaining wall built on a different foundation, base dimensions different from the tabulated values could be appropriate.

If any of the following foundation conditions exist: softness, poor drainage, filled ground, organic matter, variable conditions, heavily cracked rock, aggressive soils, then experienced professional engineering advice should be obtained.

1.6 Infill soil and retained soil

These tables have been calculated for infill soil and retained soil of soil classification shown above.

Note: The following poor quality soils are not allowed for in the tables; soft and firm clay of medium to high plasticity, silty clays, loose variable clayey fill, loose sandy silts.

If these soils are considered for use or aggressive groundwater exists an experienced professional engineer should be consulted and separate designs be obtained.

1.7 Drainage Systems

It is essential that steps be taken to prevent the soil behind the wall from becoming saturated. These steps should include:

- Sealing the soil surface – this can be done by covering it with a compacted layer of material with low permeability. The surface should be sloped towards an open drain.
- A drainage system within the soil – this should preferably be achieved by placing gravel to a width of approximately 300mm immediately behind the wall with a continuous 100mm diameter slotted pvc agricultural pipe with geo fabric sock located at the base of the wall. The outlets from the pipe must be beyond the ends of the wall unless the pipe is connected to a proper storm water drainage system. For higher walls, or in cases where excessive ground water exists it may be necessary to provide another agricultural pipe drain at mid height of the wall.

If it is not possible to discharge the drains beyond the end of the wall, weep-holes may be provided (see items for block laying following). In this case, a collecting system (e.g. spoon drains) must discharge the water into a drainage system to prevent saturation of the ground in front of the wall.

A subfloor drainage system is advisable in basements to prevent hydrostatic pressure under the floor slab.

1.8 Water Penetration

If considered necessary to reduce the passage of water through the wall, for aesthetic or other reasons such as aggressive ground water, the earth face of the wall should be treated using appropriate sealing techniques (see notes on tanking.)

1.9 Exploded View of Construction

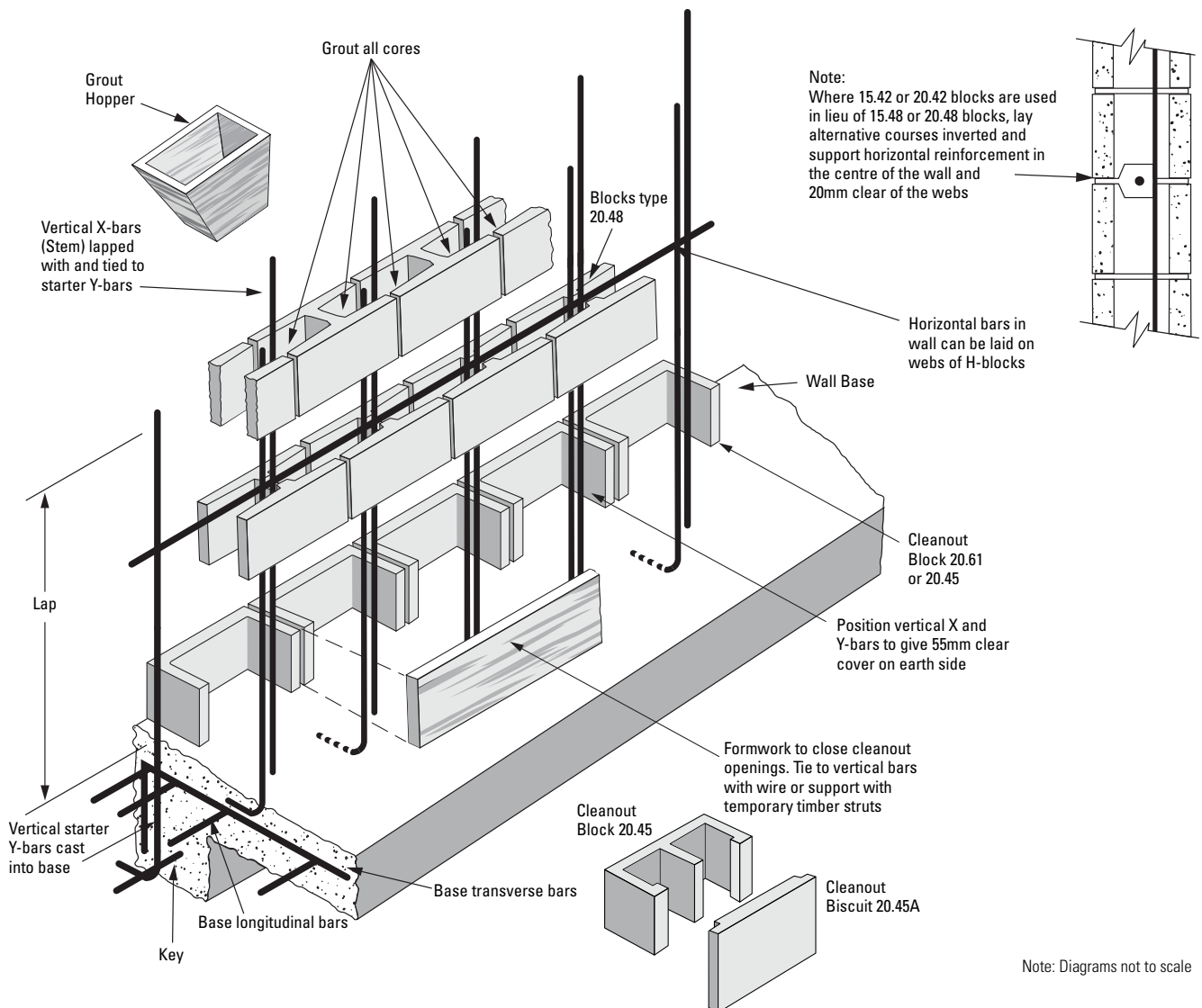

1.10 How to Build the Wall

1.10.1 Preliminary

- Excavate to a satisfactory foundation.
- Arrange for supply of materials to the specifications given previously.

1.10.2 Base

- Form the base to the required dimensions and levels as shown in tables.
- Place the base reinforcement as shown in the diagrams, securely fix the starter bars for the vertical reinforcement (Y-bars) 55mm from the back face of the wall, in the correct positions relative to the block cores to be reinforced.
- Place the base concrete, preferably using ready-mixed concrete, and compact thoroughly by rodding, spading or vibrating. Wood float finish any surface to be exposed permanently. Take care not to dislodge reinforcement.

1.10.3 Block laying

Block laying procedure follows that of the normal practice for building unreinforced walls but ensuring the required cover to the starter bars is attained. The mortar mix used should be cement 1 part, lime 1 part, sand 6 parts or cement 1 part, sand 5 parts plus water thickener. These parts should be accurately measured by volume (e.g. a bucket). The sand used should be clean pit sand, masonry or plasterer's sand. The use of plasticising additives is permitted. Where they are used, the dosage rate must not exceed that recommended by the supplier as this will drastically reduce the mortar strength. Detergent should never be used.

Recommendations specifically applicable to reinforced concrete block retaining walls follow:

- Cleanout openings should be provided in the bottom course using either 20.61 blocks plus timber formwork at the front or 20.45 blocks plus 20.45 A biscuits to permit removal of mortar fins and other debris, and to allow positioning and tying of vertical reinforcement. These openings must be closed before grouting.
- Above the first course, the use of 15.48, 20.48 and 30.48 H-Blocks is recommended because they are easier to fill with grout and provide required protection of the reinforcement. 15.42 and 20.42 blocks may be used in lieu of H-Blocks and these blocks require less grout for filling. However, they must be laid with alternative courses inverted so as to provide grout cover to longitudinal reinforcement, which must be lifted 20mm clear of the web of the block by using stirrups or other supports (see diagram).
- Mortar projecting into the cores should be removed, either as the blocks are laid, or by rodding after the mortar has set. Debris should be removed from the cores through the cleanout openings.
- When the wall is to be tanked, the mortar joints on that face should be struck flush and cleaned.
- Weepholes can be provided by passing 50mm diameter upvc pipes holes through the wall face at 1200mm centres, or installing blockwork with a void.
- Reinforcement must be positioned accurately (refer to above), and tied securely before placing concrete or grout. Vertical reinforcing bars, including starter bars, should be as close to the back face of the wall as possible, consistent with 55mm cover requirements.

Note: If starter bars have been installed out of alignment, they may be bent to regain alignment, but only if a 100mm deep hob is cast around the bent starter bar ensuring a minimum of 50mm cover is maintained. A half height unit can then be used on top of the hob.

1.10.4 Grouting

- Close cleanout openings.
- Place grout. It is recommended that whenever available, ready-mixed grout to workability specifications given in AS3700 2018 should be used. Site-mixed grout, if used, should be mixed thoroughly in a tilting drum type paddle mixer to the same specification as ready-mixed grout.
- All cores should be filled with grout, whether reinforced or not. This is essential to bond and to protect horizontal reinforcement, and to give maximum weight for stability.
- The grout should be compacted thoroughly so that voids are not left. Compaction may be by rodding with a plain round bar (do not use main vertical reinforcing bars or other deformed bars) or with a high frequency pencil vibrator, used carefully.

Note: Grout shall be placed in maximum 1800mm lifts, ensuring any cold joints that may form are positioned at mid-height of the last course being filled except at the top of the wall.

1.11 Tanking

Where the wall is required to be waterproof, for example a basement wall, various proprietary tanking methods are available. One such method is a three coat liquid rubber compound incorporating a special reinforcing fabric for high stressed areas.

Another method is a heavy duty, pliable, waterproof sheet membrane fixed to the wall surface. Surface coatings or sheet membranes must always be used in accordance with the manufacturer's specifications.

1.12 Infill Soil and Drainage

- Infill soil should not be placed behind the wall until at least 7 days after grouting.
- Infill soil should be placed and compacted in layers not more than 200mm deep. The degree and method of compaction depends on the proposed use of the retaining wall.
- The drainage system should be installed progressively as the infill soil rises.
- The drainage system behind the wall should be connected to the main drainage system.
- For the nominated infill soil in this brochure, it is advisable to seal off the top surface of the infill soil with a semi-impermeable layer of soil or earth. Compact and grade to a gutter to provide surface drainage.

1.13 Design Details for Wall Type 1

1.13.1 Level Surface Wall Layout

Walls up to 1.2m high

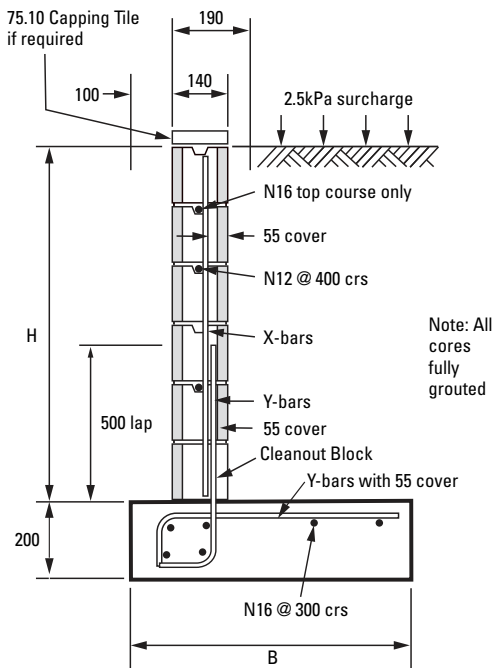

Walls over to 1.8m and up to 3.0m high

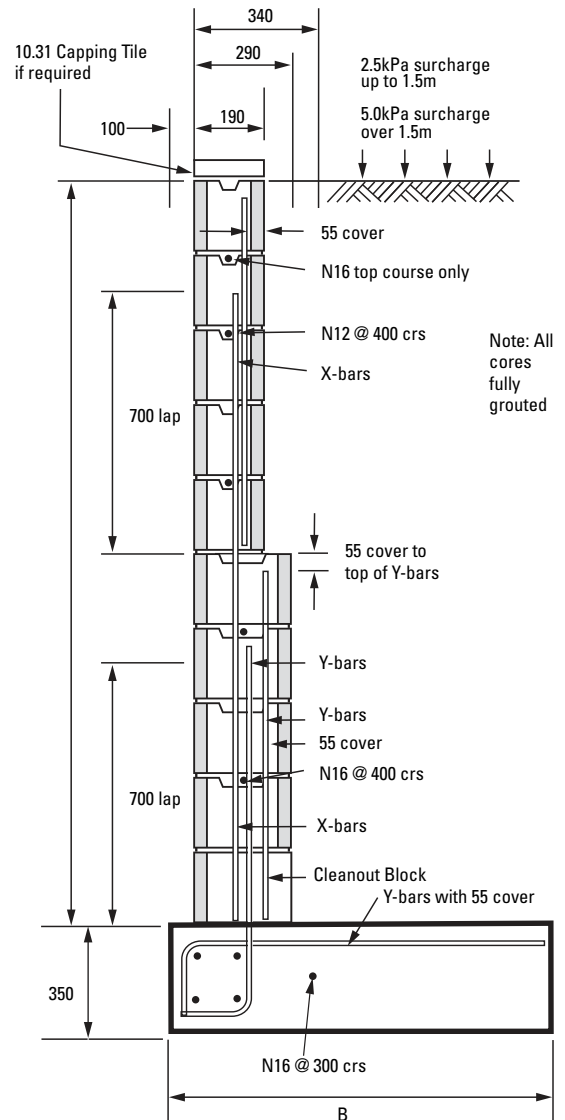

Walls over to 1.2m and up to 1.8m high

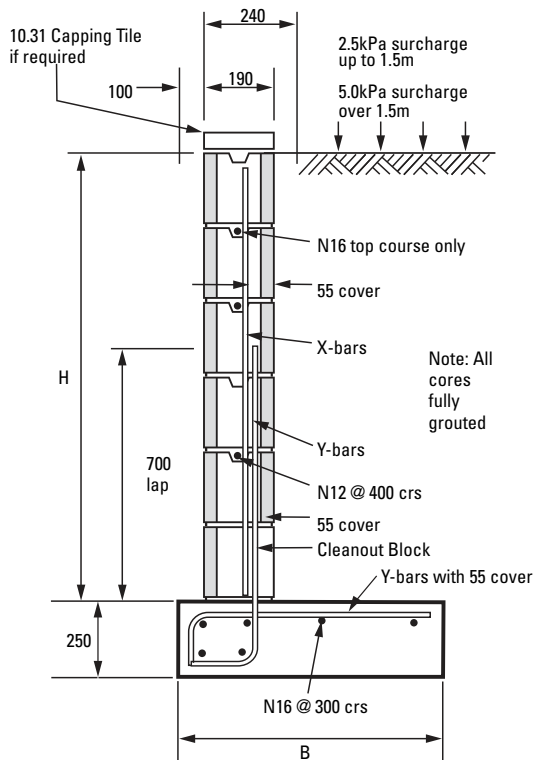

Note: Diagrams not to scale

1.13.2 Sloping Surface up to 1 in 4 Wall Layout - Wall Type 1

Walls up to 1.2m high

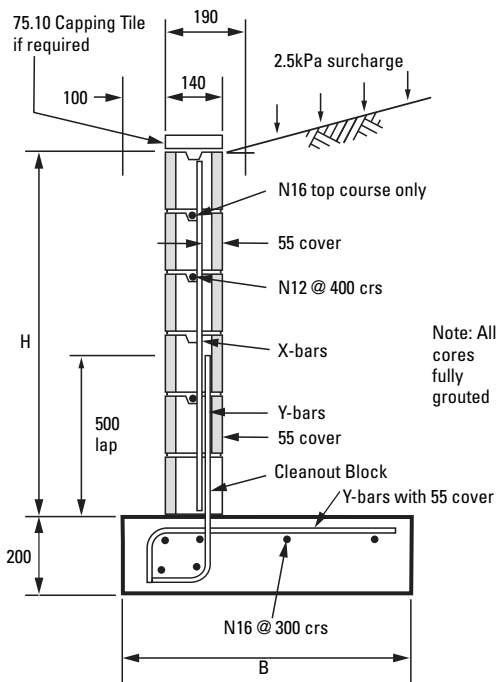

Walls over to 1.2m and up to 1.8m high

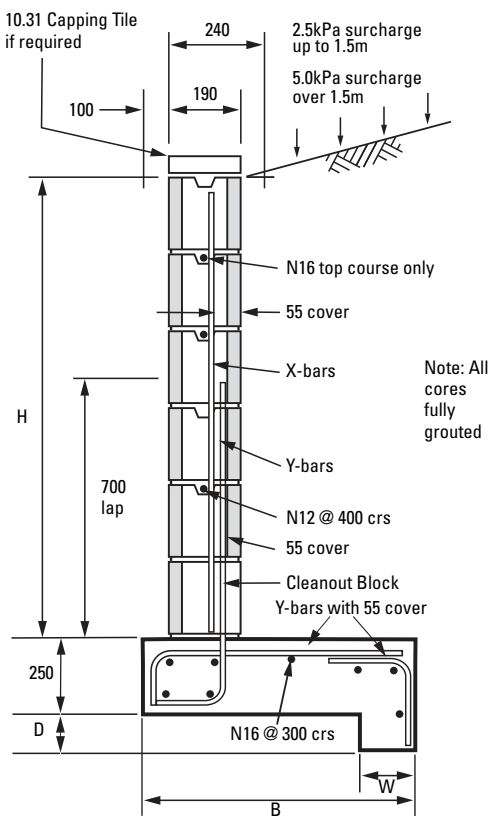

Walls over to 1.8m and up to 3.0m high

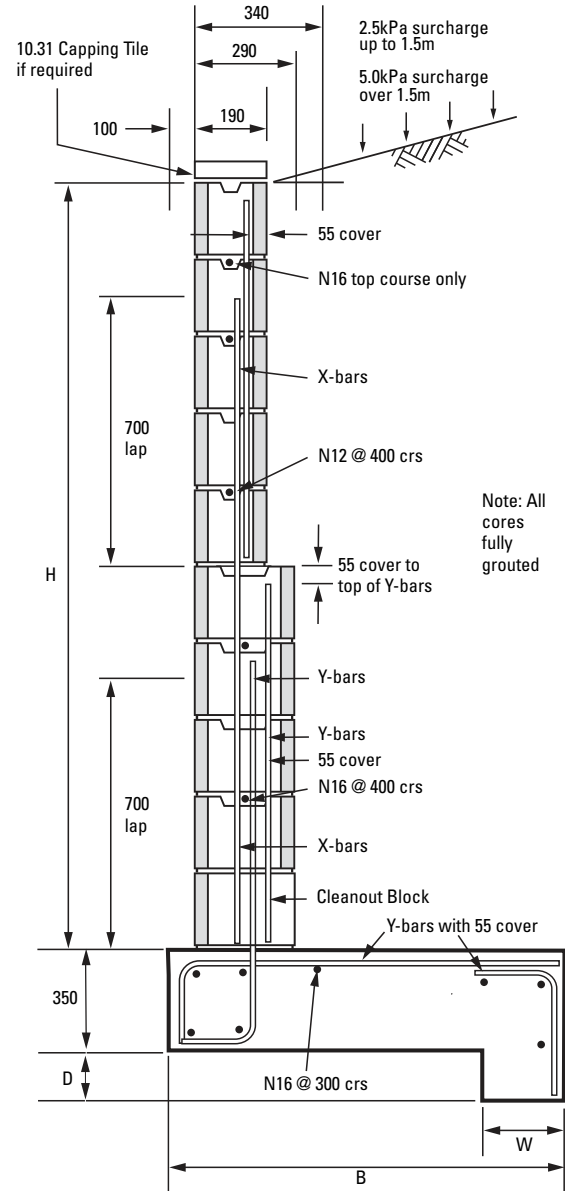

Note: Diagrams not to scale

1.13.3 Base and Key Sizes - Wall Type 1

Wall height 'H'	Base Width 'B'				Key width 'W'	Key depth 'D'
	Surface Slope				Surface slope	
	Level with		Up to 1 in 4 with		Up to 1 in 4 with	
	2.5 kPa surcharge	5.0 kPa surcharge	2.5 kPa surcharge	5.0 kPa surcharge	5.0 kPa surcharge	
600	500	-	700	-	-	
800	600	-	800	-	-	
1000	700	-	1000	-	-	
1200	850	-	1200	-	-	
1400	1000	-	1400	-	-	
1600	-	1300	-	1800	200	200
1800	-	1450	-	2200	200	250
2000	-	1650	-	2400	300	250
2200	-	1800	-	2700	300	300
2400	-	2000	-	2900	300	300
2600	-	2100	-	3200	300	350
2800	-	2250	-	3400	300	350
3000	-	2450	-	3700	300	400

Notes:

1. No key required for level surface slope walls.
2. All dimensions in millimeters.
3. 300mm of soil or a private driveway imposes a surcharge load of approximately 5 kPa.
4. 2.5 kPa surcharge applies up to 1.5m.
5. 5.0 kPa surcharge applies over 1.5m.

1.13.4 Reinforcement Details - Wall Type 1

Total wall height 'H'	Wall height			Reinforcement			
	Height of 150 series block	Height of 200 series block	Height of 300 series block	Surface slope		Surface slope	
				Level X-bar	1:4 X-bar	Level Y-bar	1:4 Y-bar
600	600	-	-	N12	N12	N12	N12
800	800	-	-	N12	N12	N12	N12
1000	1000	-	-	N12	N12	N12	N12
1200	1200	-	-	N12	N12	N12	N12
1400	-	1400	-	N16	N16	N16	N16
1600	-	1600	-	N16	N16	N16	N16
1800	-	1800	-	N16	N16	N16	N16
2000	-	1200	800	N16	N16	N16	N16
2200	-	1400	800	N16	N16	N16	N16
2400	-	1600	800	N16	N16	N16	N16
2600	-	1800	800	N16	N16	N16	N16
2800	-	1800	1000	N16	N16	N16 @ 200	N16 @ 200
3000	-	1800	1200	N16	N16	N16 @ 200	N16 @ 200

Notes:

1. All bars are to be at 400mm centres unless otherwise stated.
2. All bars to have 55mm cover from outside concrete surface.
3. All dimensions in millimeters.

1.14 Design Details for Wall Type 2

1.14.1 Level Surface Wall Layout

Walls up to 1.2m high

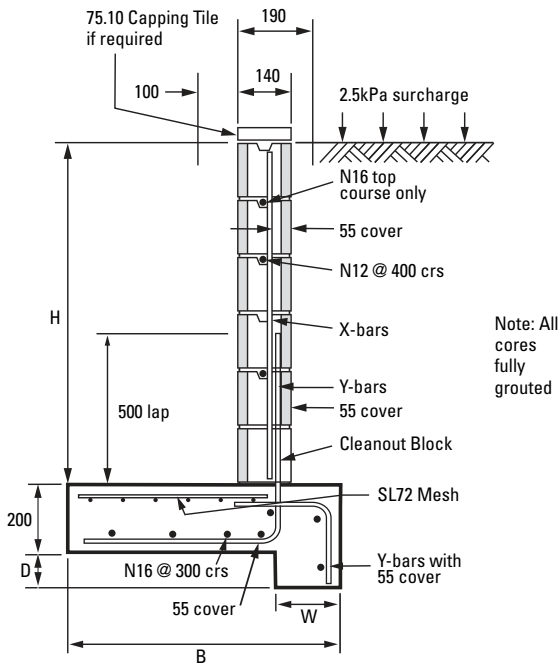

Walls over to 1.2m and up to 1.8m high

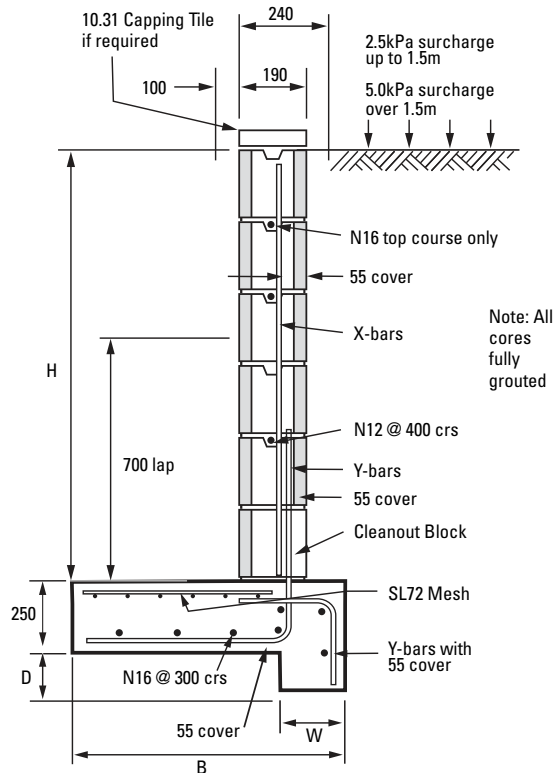

Walls over to 1.8m and up to 3.0m high

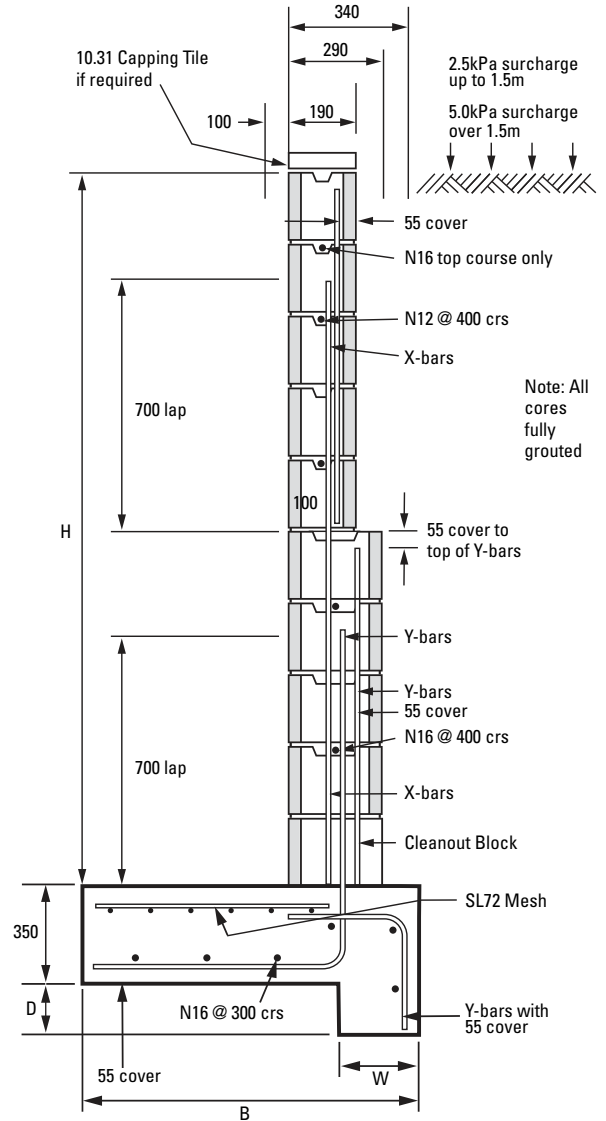

Note: Diagrams not to scale

1.14.2 Sloping Surface up to 1 in 4 Wall Layout - Wall Type 2

Walls up to 1.2m high

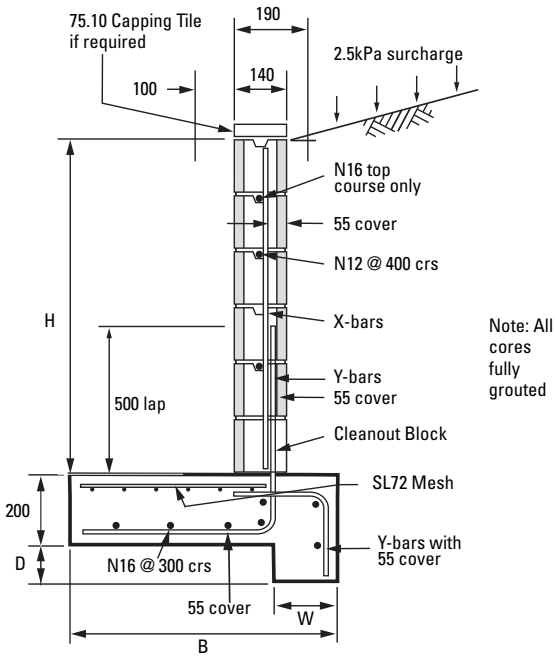

Walls over to 1.8m and up to 3.0m high

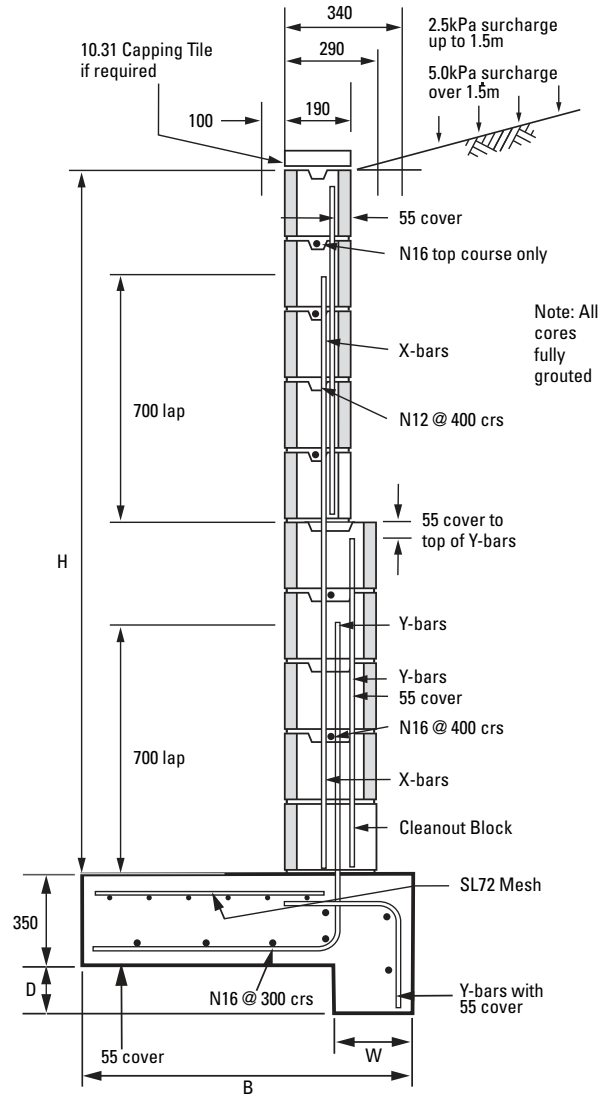

Walls over to 1.2m and up to 1.8m high

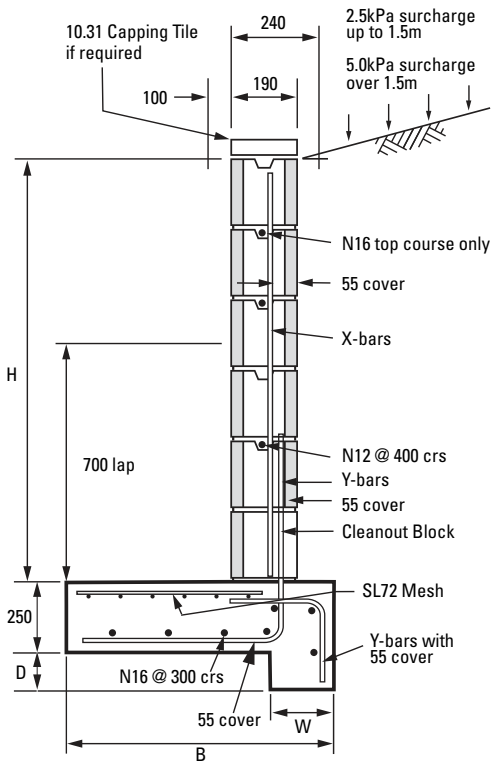

Note: Diagrams not to scale

1.14.3 Base and Key Sizes - Wall Type 2

Wall height 'H'	Base Width 'B'				Key width 'W'		Key depth 'D'	
	Surface slope				Surface slope			
	Level with		Up to 1 in 4 with		Level	1 in 4	Level	1 in 4
	2.5 kPa surcharge	5.0 kPa surcharge	2.5 kPa surcharge	5.0 kPa surcharge				
600	500	-	700	-	150	-	100	
800	800	-	900	-	150	-	200	
1000	800	-	1100	-	150	200	300	
1200	1000	-	1400	-	200	300	400	
1400	1100	-	1500	-	200	350	500	
1600	-	1600	-	2200	350	500	700	
1800	-	1900	-	2400	400	550	800	
2000	-	2000	-	2600	400	550	800	
2200	-	2200	-	2900	500	600	900	
2400	-	2400	-	3200	550	700	1000	
2600	-	2700	-	3500	600	750	1100	
2800	-	2900	-	3700	600	800	1200	
3000	-	3100	-	4000	700	900	1300	

Notes:

1. All dimensions in millimeters.
2. 300mm of soil or a private driveway imposes a surcharge load of approximately 5 kPa.
3. 2.5 kPa surcharge applies up to 1.5m.
4. 5.0 kPa surcharge applies over 1.5m.

1.14.4 Reinforcement Details - Wall Type 2

Total wall height 'H'	Wall height			Reinforcement			
	Height of 150 series block	Height of 200 series block	Height of 300 series block	Surface slope		Surface slope	
				Level X-bar	1:4 X-bar	Level Y-bar	1:4 Y-bar
600	600	-	-	N12	N12	N12	N12
800	800	-	-	N12	N12	N12	N12
1000	1000	-	-	N12	N12	N12	N12
1200	1200	-	-	N12	N12	N12	N12
1400	-	1400	-	N16	N16	N16	N16
1600	-	1600	-	N16	N16	N16	N16
1800	-	1800	-	N16	N16	N16	N16
2000	-	1200	800	N16	N16	N16	N16
2200	-	1400	800	N16	N16	N16	N16
2400	-	1600	800	N16	N16	N16	N16
2600	-	1800	800	N16	N16	N16	N16
2800	-	1800	1000	N16	N16	N16 @ 200	N16 @ 200
3000	-	1800	1200	N16	N16	N16 @ 200	N16 @ 200

Notes:

1. All bars are to be at 400mm centres unless otherwise stated.
2. All bars to have 55mm cover from outside concrete surface.
3. All dimensions in millimeters.

2.0 BASEMENT WALLS

2.1 General

The foundation slab of a basement can be modified to provide an efficient footing for a retaining wall. In addition, a concrete floor slab will provide a 'prop' to the top of the wall, simplifying the wall details compared to a timber floor.

All infill materials must be with granular material. Details of typical basement walls are shown in the following figures.

2.2 Drainage

As with all retaining walls it is critical that the soil is prevented from becoming saturated. Steps to be taken to achieve this include:

- A drainage system within the soil. This should preferably take the form of a 300 mm width of gravel immediately behind the wall with a continuous agricultural pipe located at the base of the wall. The pipe must discharge beyond the ends of the wall.
- Sealing the soil surface. This can be done by placing a compacted layer of low-permeability material over the soil and sloping the surface away from the house.

It is also important to prevent hydrostatic pressure under the floor slab. Where there is the possibility of groundwater under the slab, then a subfloor drainage system is advisable.

2.3 Tanking

Where it is required that the basement be kept dry, a proper tanking system needs to be installed behind the wall before backfilling. An alternative to this is to provide a drain and a false wall in front of the wall.

2.4 How to Build the Wall

Building a Basement wall is essentially the same as building a retaining wall. Please refer to section 1.10 for details on how to build a retaining wall.

2.5 Basement Walls

Unpropped or partially propped wall

Basement walls up to 2.7m high.

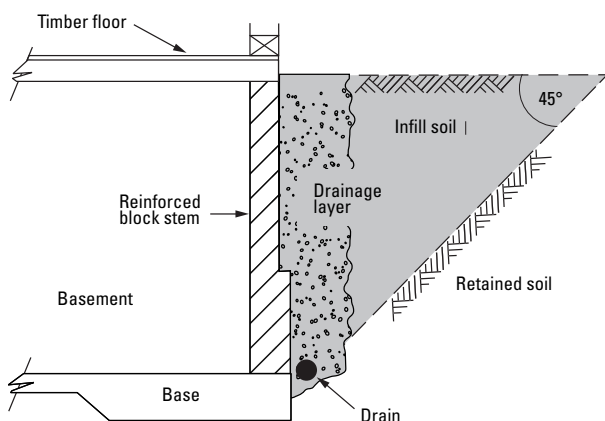

Propped wall

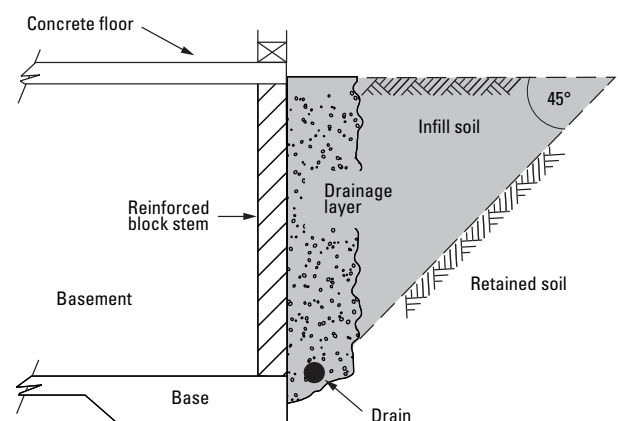

Note: Diagrams not to scale

2.6 Block Basement Wall Design Details For Supporting a Concrete Wall

Typical details - Fully-propped walls

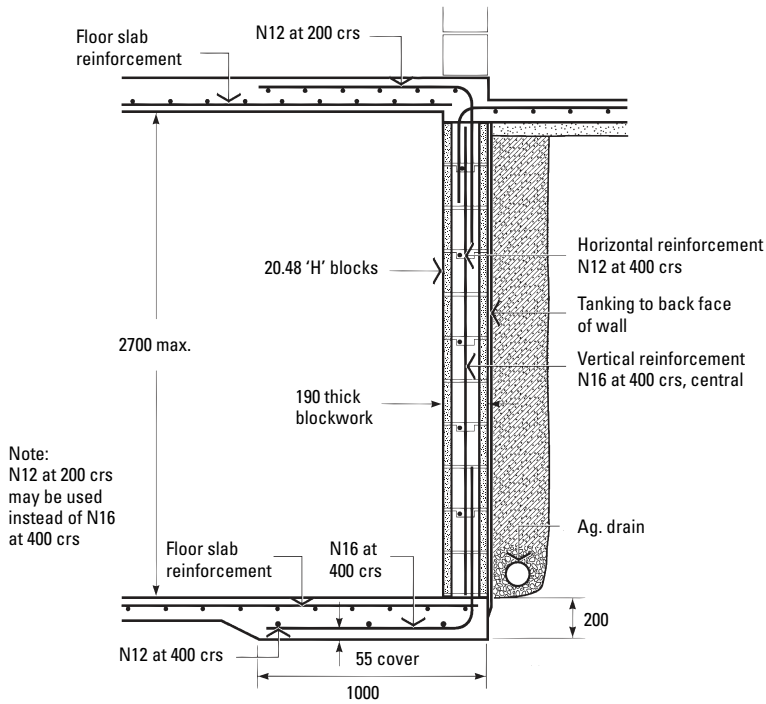

Alternative details

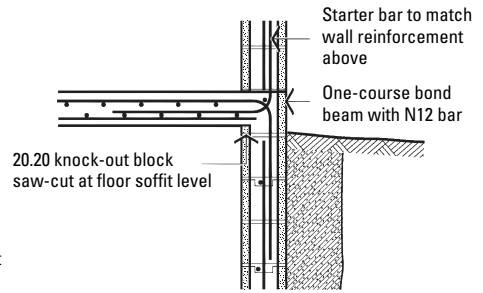

Note:
Wall blocks and reinforcement as for 'Typical Details' - fully propped walls

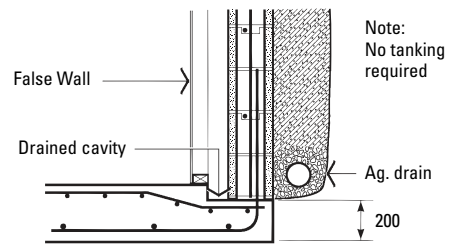

2.7 Block Basement Wall Design Details For Supporting a Timber Floor

Typical details - Unpropped or partially-propped walls

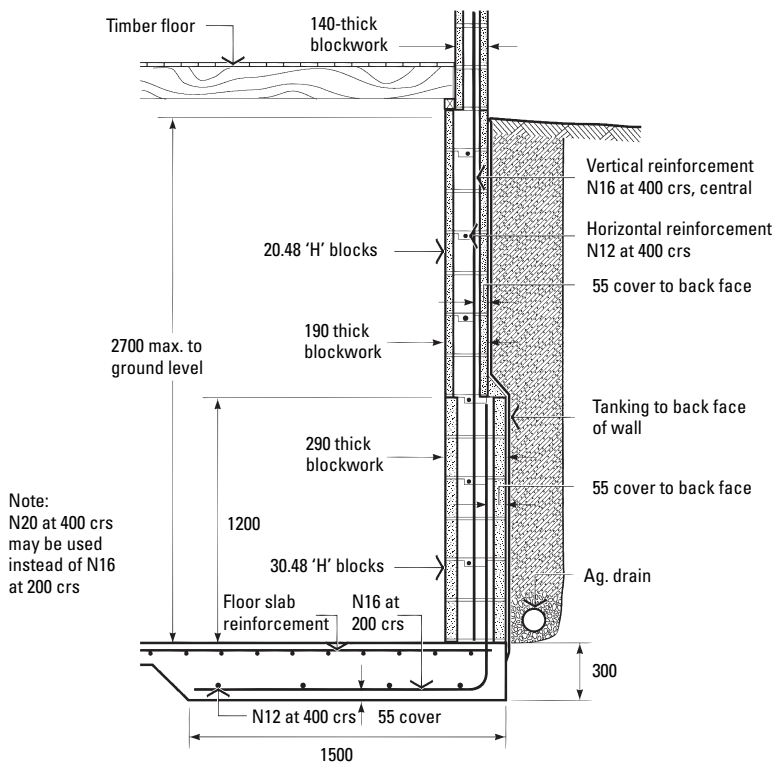

Alternative details

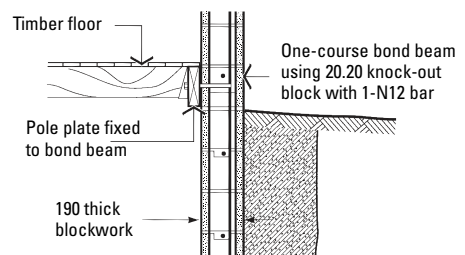

Note:
Reinforcement as for 'Typical Details'

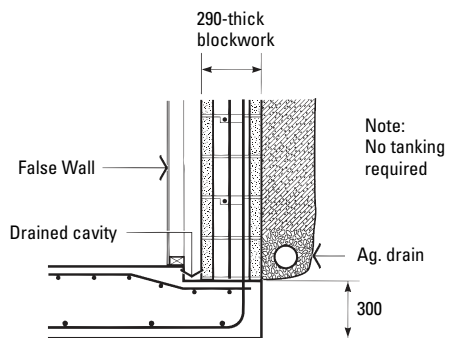

Note: Diagrams not to scale

GLOSSARY

2.8 Basement Walls

These designs are based on a level surface with 5 kPa surcharge. Walls designed as propped must not be backfilled before the concrete floor at the top of the wall is in place.

Important Notes

No loadings should be applied (e.g. from footings), within the area of infill soil other than those loadings referred to above.

The area of infill soil is bounded by a line at 45° to the rear of the base as illustrated in chapter 1.

Only one typical soil case is presented. These tables may not provide an ideal solution in a particular case.

For situations other than those covered by the tables, or if there is doubt as to the strength and stability of the foundation material or the drainage system needed, an experienced professional engineer should be consulted for advice.

Load and Limit States:

Dead load*

The self-weight of the structure, infill soil, retained soil or rock.

Live load*

Loads that arise from the intended use of the structure, including distributed, concentrated, impact and inertia loads. It includes construction loads, but excludes wind and earthquake loads.

Surcharge

A uniformly distributed external load. For retaining walls under 1.5m a minimum load of 2.5 kPa. For retaining walls over 1.5m a minimum load of 5 kPa.

Stability limit state

A limit state of loss of static equilibrium of a structure or part thereof, when considered as a rigid body.

Strength limit state

A limit state of collapse or loss of structural integrity of the components of the retaining wall.

Serviceability limit state

A limit state for acceptable in-service conditions. The most common serviceability states are excessive differential settlement and forward movement of the retaining wall.

Components:

Concrete masonry units

Concrete blocks manufactured to provide an attractive, durable, stable face to a retaining wall. The recommended block types are the 15.48, 20.48 and 30.48 'H' blocks.

Retained soil

The natural soil, intended to be retained by a retaining wall.

Foundation soil

The natural soil material under a retaining wall.

Infill soil

The soil material placed behind the retaining wall facing. Often retained soil is used for this purpose.

* This brochure uses the terminology 'dead load' to indicate permanent loads and 'live load' to indicate imposed loads. This terminology is consistent with the convention adopted in AS 4678-2002.



BRICKS

| BESSER® BLOCKS

| PAVERS

| RETAINING WALLS

Adbri Masonry is Australia's largest supplier of quality masonry products.

BESSER is a registered trademark of Adbri Masonry Pty Ltd or its related entities.

Adbri Masonry manufactures a large range of concrete products such as; bricks, block and architectural coloured block, decorative wall claddings, retaining wall systems, concrete and wetcast pavers as well as an exceptional range of environmental products. These products are used in many large scale civil projects as well as in thousands of backyards throughout Australia.

Adbri Masonry is a wholly owned subsidiary of Adelaide Brighton Ltd.

Adbri Masonry was formed in July 2008, bringing together two reputable brands, C&M Brick and Hanson Building Products. Both Hanson Masonry and C&M Brick boast proud histories and both have been foundation companies whose products have helped to build the face of the Australia we now know. From Hanson pavers in Cairns Airport to C&M Brick's paving in the Homebush Olympic village, many of Australia's iconic projects have utilised the quality products from these two trusted companies.

For further advice, talk to your local Adbri Masonry Landscaping Solutions Specialist.

Contact Us



adbrimasonry.com.au



1300 365 565



enquiries@adbri.com.au

Reinforced BESSER® Block Retaining Walls

April 2020

Adbri Masonry Pty Ltd
ABN: 31 009 687 521

The Adbri Masonry logo is a registered trademark of Adbri Masonry Pty Ltd.

adbriMASONRY
working together