

CMAA

CONCRETE MASONRY
ASSOCIATION OF AUSTRALIA

CM01

Concrete Masonry –
Handbook



While the contents of this publication are believed to be accurate and complete, the information given is intended for general guidance and does not replace the services of professional advisers on specific projects. Concrete Masonry Association of Australia cannot accept any liability whatsoever regarding the contents of this publication.

Copyright © Concrete Masonry Association of Australia 2019.

ABN 33 065 618 804.

This publication, its contents and format are copyright of the Concrete Masonry Association of Australia, and may not be reproduced, copied or stored in any medium without prior, written authorisation from the Institute. Concrete Masonry Association of Australia is wholly sponsored by the Australian concrete brick, block and paver industry. Local or state regulations may require variation from the practices and recommendations contained in this publication.

Revised and Republished 2019.

The Standards referenced in this manual were current at the time of publication.

Product: Austral Masonry GB Honed®



PO Box 275, St Leonards NSW 1590 Australia
Suite 7.01, Level 7, 154 Pacific Highway, St Leonards NSW 2065 Australia
Telephone +61 2 8448 5500
Technical hotline 1300 667 617
ABN 30003873309

www.cmaa.com.au

1.	Principal Differences between Blockwork and Brickwork	1
1.1	Size	1
1.2	Material and Dimensional Variation	1
1.3	Mortar	1
1.4	Mortar Joints	1
1.5	Control Joints	2
1.6	Grout filling and Reinforcement	2
2.	Block Coding System	2
3.	Mortar and Mortar Joints	6
3.1	Mortar	7
3.2	Mortar Joints	7
4.	Corner Bonding	8
5.	Engaged Piers	9
6.	Modular Planning	10
7.	Estimating Data	14
8.	Control Joints	14
9.	Articulated Designs (or Panel Construction)	16
10.	Finishes and Treatments of Concrete Masonry Walls	17
10.1	Finishes to External Walls	17
10.2	Finishes to Internal Walls	17
10.3	Surface Preparation	17
10.4	Special requirements for Single-leaf masonry System	17
11.	Applications for Reinforced Blockwork	18

12.	Grout Filling	20
	12.1 Introduction	20
	12.2 Grout Specification	20
	12.3 Grouting	20
13.	The 200 mm Single-Leaf Masonry System – How it Works	21
14.	Single-Leaf Masonry Estimating Worksheet	24
15.	Cleaning of Masonry	26
	15.1 Good Practice	26
	15.2 Mortar Smears	26
	15.3 Stains	26
	15.4 Iron Oxide Stains	26
	15.5 Hardwood Timber	26
	15.6 Softwood Timber	26
	15.7 Clay or Loam Stains	26
	15.8 Mosses, Moulds and Lichens	26
	15.9 Efflorescence	26
	15.10 Calcium Carbonate (heavy deposits)	27
	15.11 Hydrochloric Acid	27
16.	Australian Standards and Building Code of Australia	27

1. Principal Differences between Blockwork and Brickwork

Masonry is the word used to describe walls built out of masonry units laid on a mortar bed.

Masonry Units are commonly called:

- Blocks (which are generally large hollow units) and;
- Bricks (which are smaller units, either solid or with small cores).

The masonry built with these units is generally referred to as *blockwork* and *brickwork*.

There are many differences between these two forms of masonry units laid on a *mortar bed*.

1.1 Size

The Block most commonly used is hollow and is often referred to by its nominal size i.e., 400 mm long, 200 mm wide and 200 mm high. Because an allowance is made for 10 mm wide mortar joints, the actual size of the block is 390 mm x 190 mm x 190 mm. To avoid the need for cutting, 3/4, 1/2 and 1/4 length blocks are made which are called specials. Other specials are made to form lintels, control joints etc.

The range of blocks with a Nominal width of 200 mm is referred to as the 200 mm Series. Less commonly used blocks are the 100 mm, 120 mm, 150 mm and 300 mm series. Some blocks in the 100 mm series are solid. Note that a building module 600 mm x 600 mm contains three courses of 1 1/2 blocks = 4 1/2 blocks, see **Figure 1**.

Bricks are usually solid or cored and generally made to a traditional size, 230 mm long, 110 mm wide and 76 mm high. These are the actual dimensions and nominal sizes are not quoted for bricks. It should be noted however that allowing for 10 mm joints, a building module 600 mm x 600 mm contains seven courses of 2 1/2 bricks = 17 1/2 bricks, see **Figure 1**.

1.2 Material and Dimensional Variation

Blocks are generally made of concrete. Because they are formed in steel moulds and the material is relatively stable, the size of individual units can be controlled to within small tolerances. Bricks are often made of clay. They can undergo shape changes during manufacture, particularly in the firing process, and individual units can vary considerably in size. Tolerances are measured by placing 20 units together, which measures the average size, but not the variation of individual units.

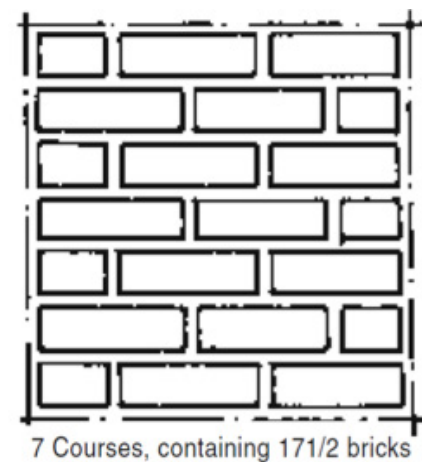
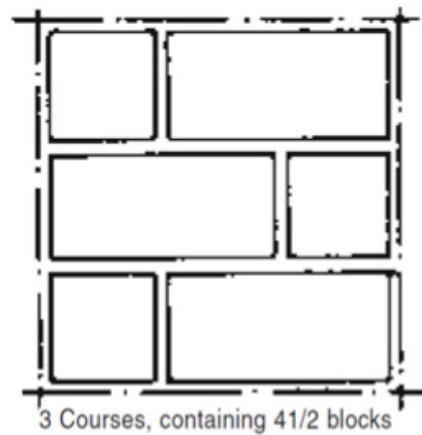

Figure 1 Number of blocks and bricks in a 600-mm building module

1.3 Mortar

The sand used in making the mortar used for blockwork should not be the same as commonly used in mortar for brickwork. “Brickies loam” contains clay particles which make the mortar more workable, but also causes high shrinkage in the mortar. Clay masonry units tend to expand, which compensates for the shrinkage in the mortar. Concrete masonry units shrink, so that if they are used with a mortar with high shrinkage, cracking may result.

For this reason, the sand used in mortar for concrete blockwork should be clean sharp sand, such as clean pit sand, masonry sand or plasterer’s sand. Tests have shown that the sand can contain up to 10% fines but it should not contain any clay particles. (See **Clause 3 Mortar and Mortar Joints**)

1.4 Mortar Joints

Hollow blocks are normally laid with face shell bedding ie, there are two strips of mortar which are laid over the face shells with no mortar being laid on the web. These two strips of mortar are continued up the vertical (or perpend) joints. Bricks are laid on a full bed of mortar and with a full perpend. (See **Clause 3 Mortar and Mortar Joints**)

1.5 Control Joints

Because there is some shrinkage in a concrete masonry wall after it is constructed, it is necessary to provide control joints in blockwork to prevent cracking due to that shrinkage.

Control joints are required in clay masonry to allow for the expansion of clay and they are referred to as expansion joints. It is most important that these joints be thoroughly cleaned out and be sufficient width so that they allow the bricks to expand freely. (See **Clause 8 Control Joints**)

1.6 Grout filling and Reinforcement

Because concrete blocks are hollow and the cores are large, it is possible to pour grout (ie, fluid concrete) into them. When reinforcing rods are also placed in the cores, the resulting combination of block + grout + reinforcement is called “reinforced masonry”.

Reinforced masonry is very much stronger than normal masonry in its resistance to bending and it is widely used for the construction of large external wall panels, lintels, retaining walls, swimming pools etc. (See **Clause 12 Grout Filling**)

2. Block Coding System

Because of the wide range of block sizes and “specials” produced, the Concrete Masonry Association of Australia (CMAA) introduced a common coding system. Although there are some variations between companies you can order a particular size and shape of block by the same code number.

The principle of the system is that the first two numbers of the code number refer to the width of the block ie, 20.01 is in the 200 series (200 mm nominal width) and 15.02 is in the 150 series (150 mm nominal width).

The numbers following after the full stop refer to the length on other special features of the block. Thus, in the above examples;

20.01 is a standard block (400 mm nominal length)

15.02 is a 3/4 length block (300 mm nominal length)

Other examples of the code system are:

20.03 is a 1/2 length block

20.04 is a 1/4 length block

20.12 is a lintel block

20.20 is a knock-out bond beam block

These are all blocks in common usage and generally available everywhere. However, while the coding system is the same in all areas, the range of blocks available “ex-stock” is not necessarily the same because of different local building techniques. The range of blocks generally available are illustrated on the following pages. Availability of block types should always be checked. The range of block widths is illustrated in **Figure 2**.

The 200 series block is by far the most commonly used and the 20.01 represents well over half of total block usage. The Series is used principally for single-leaf external walls and retaining walls. Most houses in North Queensland are built with 200 series blockwork. In most cases 200 series blockwork is reinforced.

100 mm **SERIES**

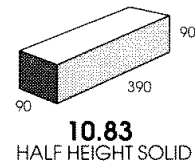
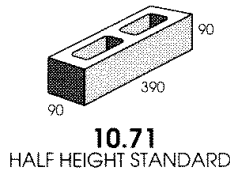
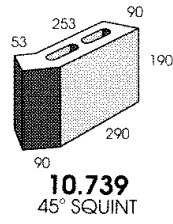
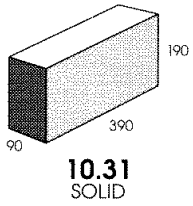
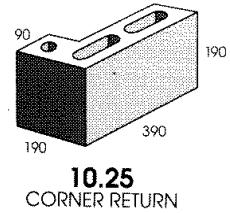
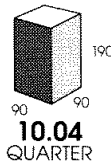
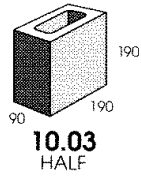
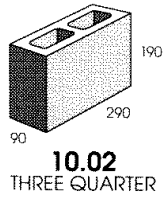
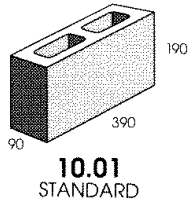

120 mm **SERIES**

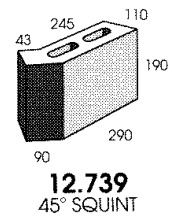
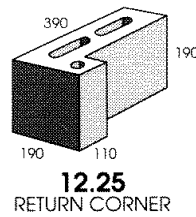
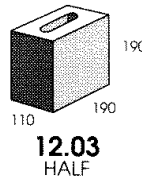
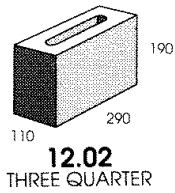
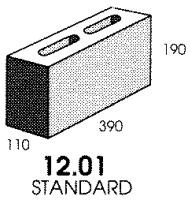

150 mm **SERIES**

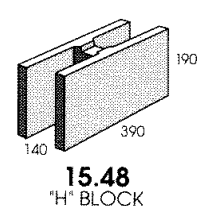
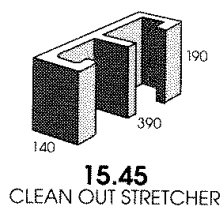
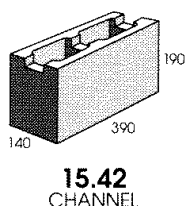
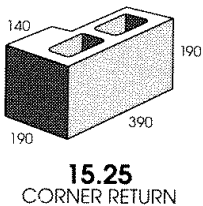
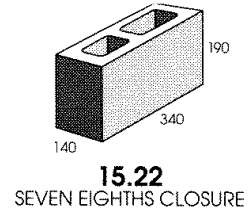
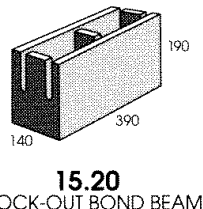
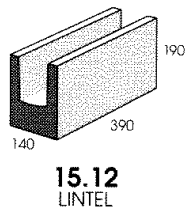
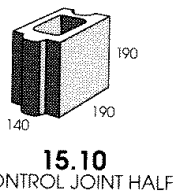
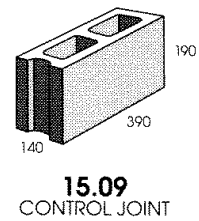
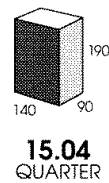
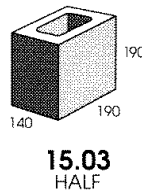
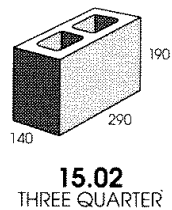
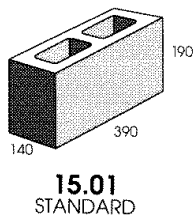
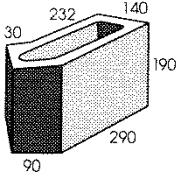
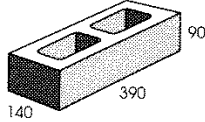

Figure 2 Range of standard block widths

150 mm **CONTINUED**



15.739
45° SQUINT



15.71
HALF HEIGHT
STANDARD

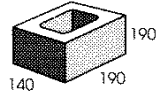

15.73
HALF HEIGHT

NOTE: The blocks shown on these pages are for illustration purpose only and not necessarily available at all locations

200 mm **SERIES**

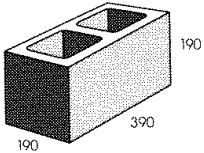

20.01
STANDARD

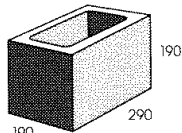

20.02
THREE QUARTER

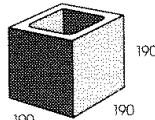

20.03
HALF

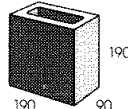

20.04
QUARTER

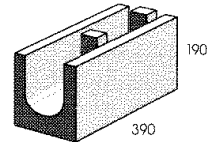

20.12
LINTEL

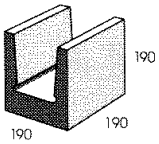

20.13
HALF LINTEL

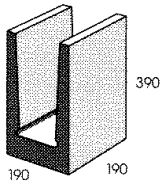

20.18
DEEP LINTEL

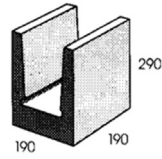

20.26
THREE-QUARTER LINTEL

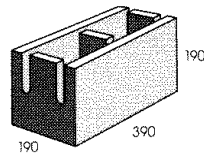

20.20
KNOCK OUT BOND BEAM

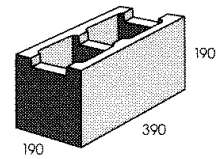

20.42
CHANNEL

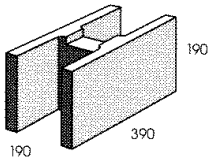

20.48
"H" BLOCK

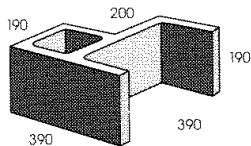

20.60
BONDED PIER

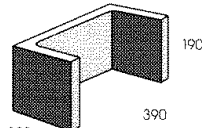

20.61
PIER

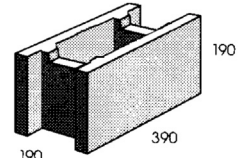

20.91
DOUBLE "U" RETAINING WALL BLOCK

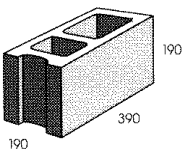

20.09
CONTROL JOINT

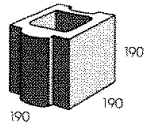

20.10
CONTROL JOINT HALF

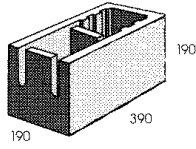

20.21
KNOCK-OUT BOND BEAM

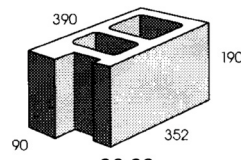

20.23
JAMB-FULL LENGTH

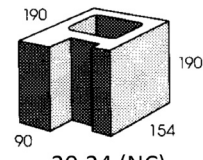

20.24 (NC)
JAMB-HALF

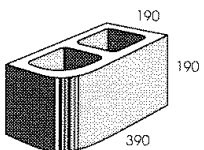

20.713
BULLNOSE

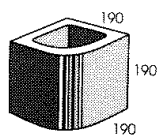

20.715
BULLNOSE HALF

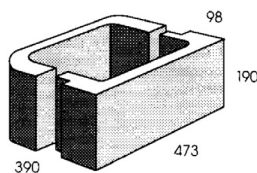

20.56
PIASTER

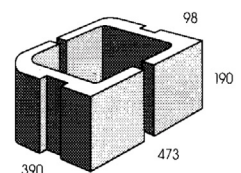

20.57
PIASTER WITH CONTROL JOINT

200 mm **CONTINUED**

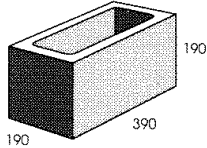

20.925
SINGLE CORE

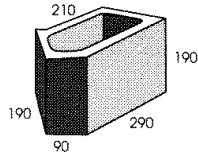

20.739
45° SQUINT

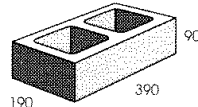

20.71
STANDARD

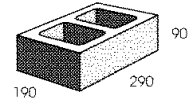

20.72
THREE QUARTER

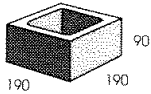

20.73
HALF

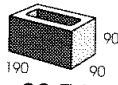

20.74
QUARTER

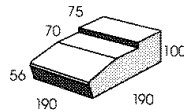

20.38
SILL (HALF HEIGHT)

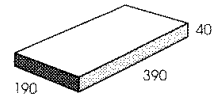

50.31
CAPPING TILE

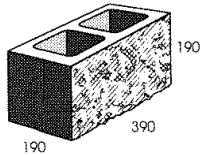

20.121
STANDARD

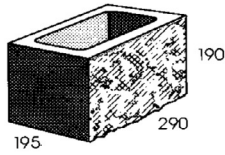

20.122
THREE QUARTER

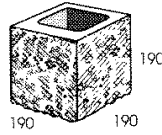

20.123
HALF

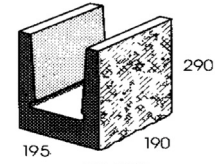

20.126
THREE-QUARTER LINTEL

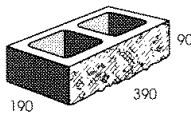

20.127
HALF HEIGHT

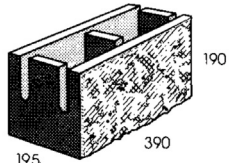

20.120
KNOCK-OUT BOND BEAM

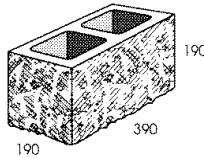

20.139
CORNER

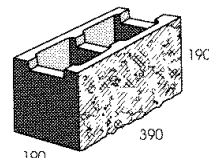

20.142
CHANNEL

300 mm **SERIES**

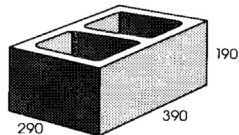

30.01
STANDARD

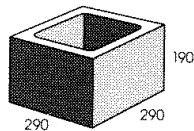

30.02
THREE QUARTER

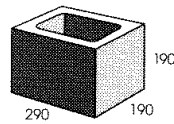

30.03
HALF

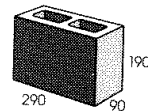

30.04
QUARTER

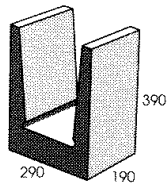

30.18
DEEP LINTEL

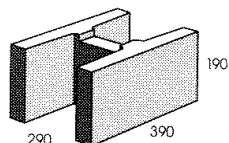

30.48
"H" BLOCK

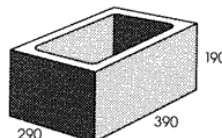

30.925
SINGLE CORE

3. Mortar and Mortar Joints

3.1 Mortar

The three principal functions of mortar are:

- To provide an even bedding for the blocks and allow course levels by taking up small variations in unit height.
 - To transmit compressive loads.
 - To hold the blocks together in the wall by bonding to them, so that tensile and shear forces can be carried. (This is often referred to as a “bond strength”). This is particularly important so that units on top of a wall are not easily dislodged.
- An appropriate mortar mix design should be selected, see Table 1.
 - The mortar should be batched accurately using some consistent form of volume measurement.
 - The sand used in the mortar should be clean pit sand, masonry sand or plasterer’s sand. Clayey loam or sand containing organic impurities will affect the mortar strength and should not be used.
 - Mortar should be discarded and not retempered, after the initial set of the cement has taken place.
 - Admixtures. Caution should be exercised when using plasticisers or workability agents. They should only be used if specified by the architect or engineer and then strictly in accordance with manufacturer’s instructions. Detergent should never be used.

In order to provide a good bond between the units and the mortar, the following guidelines should be followed:

Table 1 Mortar types and mixes

Mortar Type	GP Portland or GB Blended Cement	Building Lime	Sand	Methyl Cellulose added ^{Note 1}	Where Used
M3	1	1	6	Optional	General purpose application with moderate exposure including: <ul style="list-style-type: none"> • All general purpose blockwork above the DPC. • Below the DPC in non-aggressive soils. • Greater than 100 m from non surf coast • Greater than 1 km from surf coast • Blockwork standing in fresh water or non-saline wetting and drying. • Fireplaces, barbecues and incinerators
	1	0	5	Yes	
M4	1	0.5	4.5	Optional	High durability applications with severe exposure including: <ul style="list-style-type: none"> • Below DPC in aggressive soils. • Severe marine environment up to 100 m from a non-surf coast. • Severe marine environment up to 1 km from a surf coast. • Blockwork standing in saline or contaminated water including tidal and splash zones. • Blockwork within 1 km of an industry in which chemical pollutants are produced.
	1	0	4	Yes	

Note:

- 1 Methyl Cellulose water thickener is used to prevent the rapid drying out of the mortar thus improving its workability as well as increasing bond strength. It does not have the detrimental effect of the plasticisers. It is available under the trade name of DYNEX or similar.
- 2 While this table provides an overall general guide to where mortar is used, the Australian Standard for Masonry Structures AS 3700 has detailed specific requirements for where both the mortar and masonry units can be used.

3.2 Mortar Joints

The mortar bed on both horizontal joints and perpend extends only for the width of the face shell. Most blocks have a tapered core and are laid with wider part of face shell to the top. (See *Figure 6*)

Joint Finishing

The preferred finish for mortar joints in face blockwork is an ironed finish. (See *Figure 6*)

This finish is obtained by ironing the joints with an ironing tool when the mortar is firm to the touch (about 20-30 minutes after laying) and then lightly scraping off the surplus mortar with the trowel, or by lightly brushing. (See *Figure 5*)

The ironing tool should be made of 12 mm diameter round rod and be more than 400 mm long to ensure that a straight joint is produced.

The reasons that the ironed finish is preferred are:

- The ironing tool compresses the mortar at the face of the masonry and thus makes it denser and more durable.
- The mortar is pushed against the top and bottom faces of the blocks, thus improving the bond between the mortar and the block where it matters most.

However, where a plaster or textured coating is to be applied to the blockwork, a flush joint may be used. This may be produced by rubbing the surface with a piece of block when the mortar is firm to provide a flat surface under the coating. (See *Figure 7*)

Also, a 3–5 mm raked joint can be used as an aid to forming a key for solid render. (See *Figure 8*) Raked joints should never be used with hollow blocks, which are not to be rendered because:

- The width of face shell mortar would be reduced.
- The weatherproofing would be adversely affected.

Note: Raked joints are used in face brickwork for aesthetic reasons.



Figure 3 *Mortar applied to the face-shells*

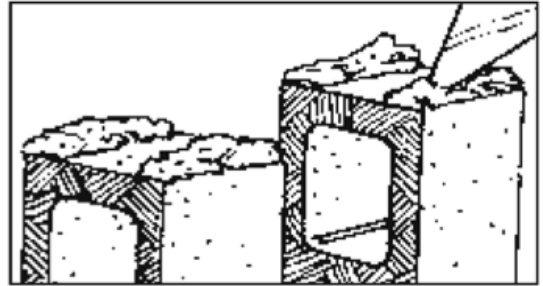

Figure 4 *Mortar applied to the perpend*

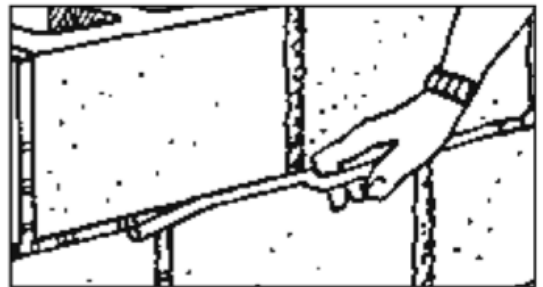

Figure 5 *Ironing the joints with an ironing tool*

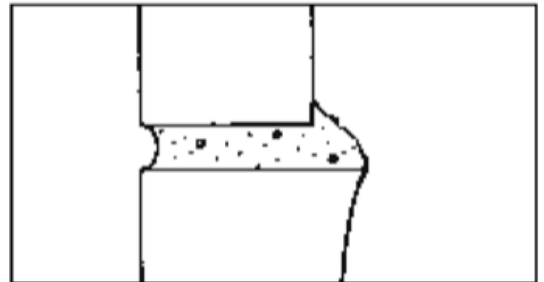

Figure 6 *Ironed finish (face-shell cross section)*

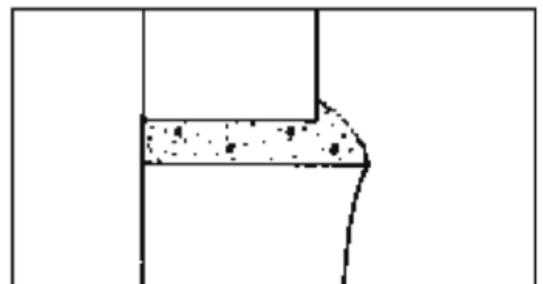

Figure 7 *Flush finish (face-shell cross section)*

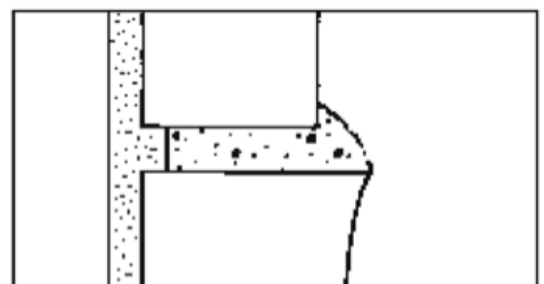

Figure 8 *Raked finish with render*

4. Corner Bonding

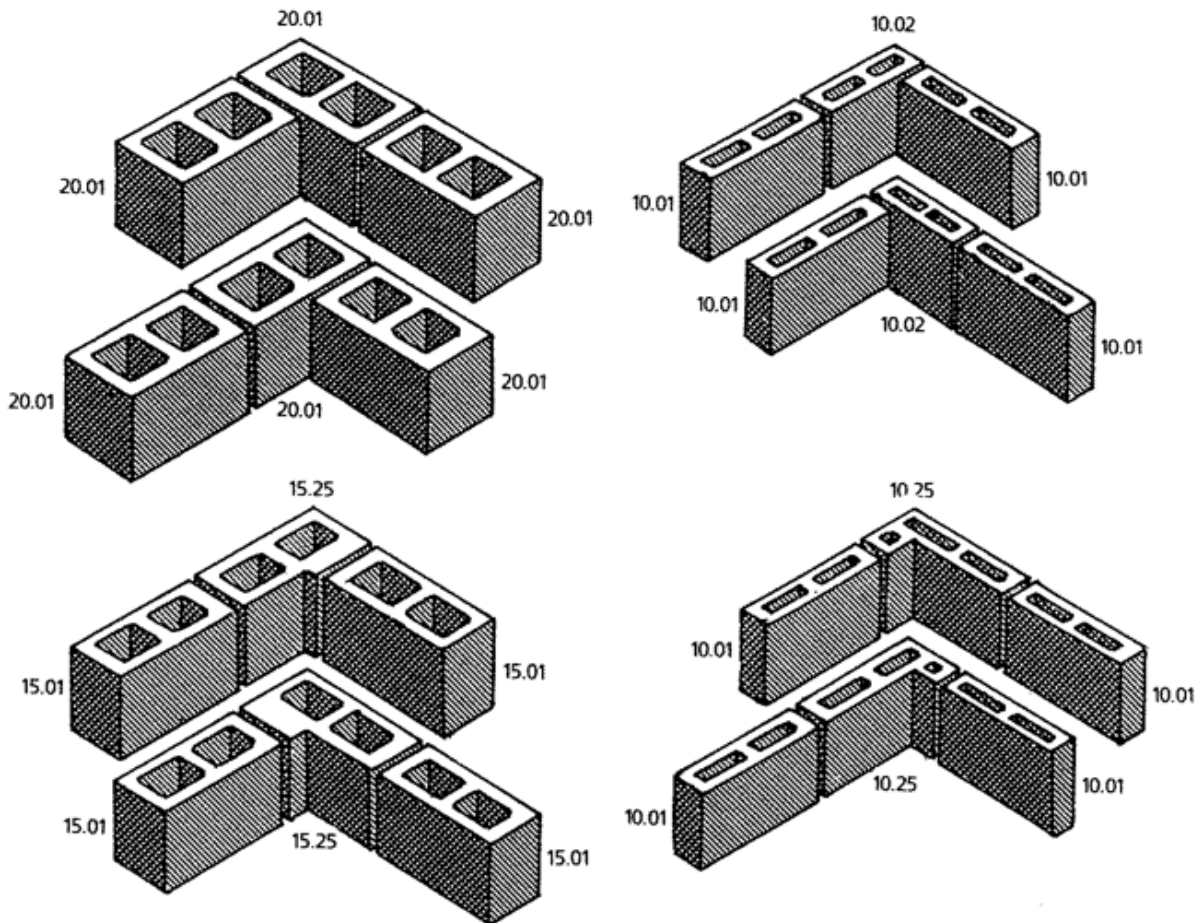

Figure 9 Typical hollow-block corner details

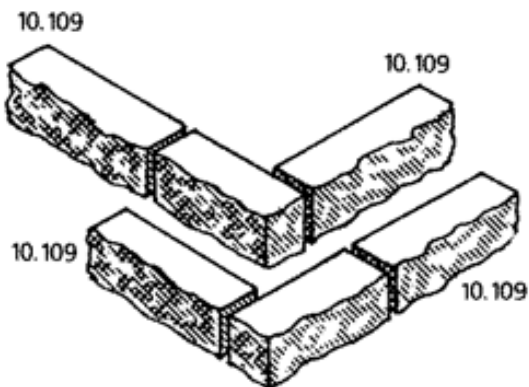

Figure 10 Typical split-block corner details

5. Engaged Piers

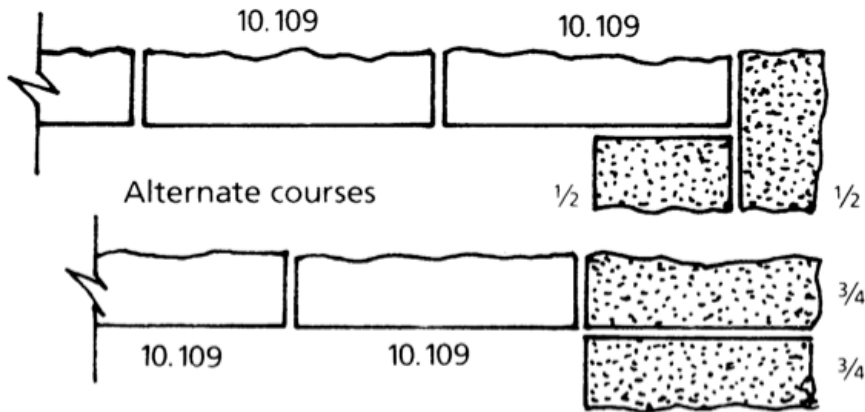

Figure 11 Pier at end of 100 mm split-block wall

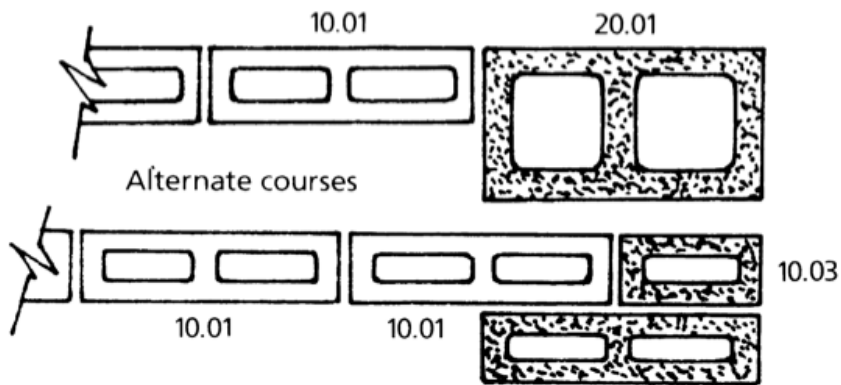

Figure 12 Pier at end of 100 mm hollow-block wall

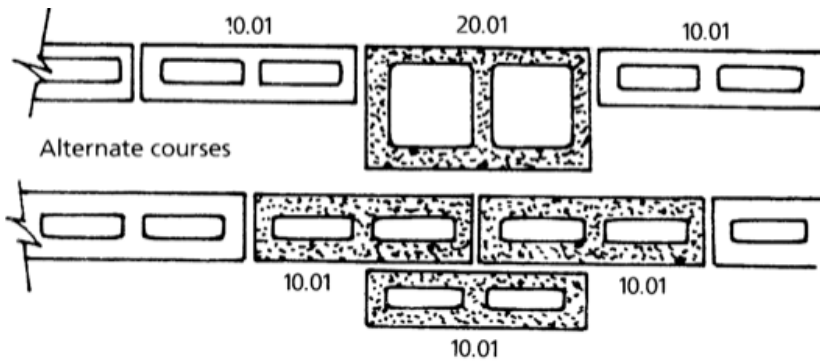

Figure 13 Engaged pier in 100 mm hollow-block wall

6. Modular Planning

The concrete block was one of the first building components to be designed with modular construction in mind. Originally it was based on a 100 mm module (it remains 4" in the USA) but when the metric system was adopted in Australia during the 1970s, this was changed to a 300 mm module.

Providing the design of a building is based on this module, no cutting of blocks is required. Since most other building materials are now supplied in sizes that are multiples of 100 mm, this is generally not a problem. The preferred height dimensions are based on this module. See **Figure 14**.

Nominal widths of doors and windows are also based on this module e.g. 900 mm wide single door, 1200 mm, 1800 mm 2400 mm windows and doors.

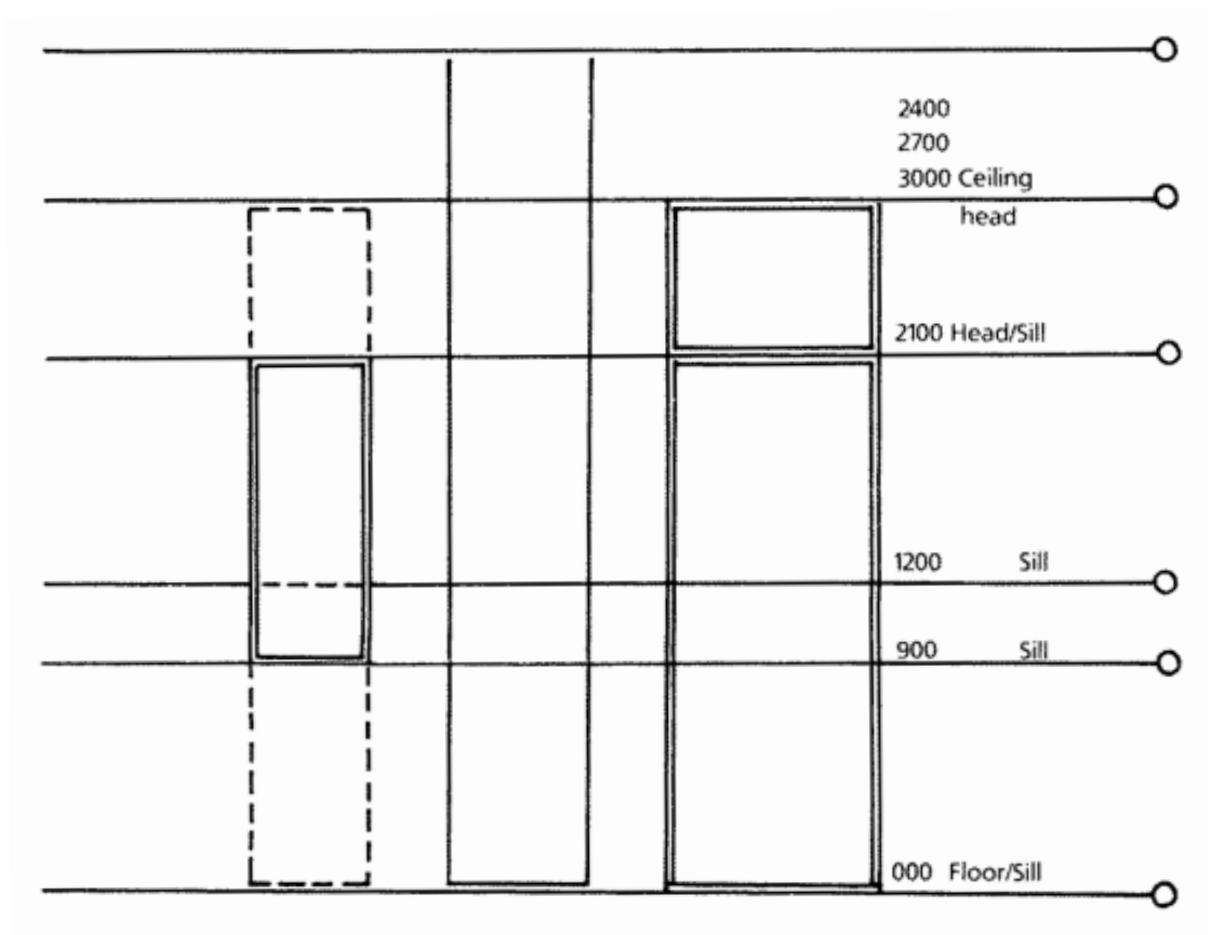

Figure 14 Vertical modular dimensions

The preferred way of dimensioning drawings is to show these nominal sizes on openings, as shown in Figure 15.

However, because the blocks are made 10 mm shorter than the nominal (or modular) size, the actual openings will be as shown in Figure 16.

For this reason, window and door frames are manufactured to suit openings which are 10 mm wider than the module e.g. 910 mm, 1210 mm, 1810 mm, 2410 mm.

The length of piers and walls are also 10 mm less than the modules i.e. 890 mm, 1790 mm etc.

200 mm Module

It is recommended to plan a building using a 200 mm or 400 mm module, as significant reduction in the number of “special” blocks is achieved. Also, the cores in the blocks line up for grout filling.

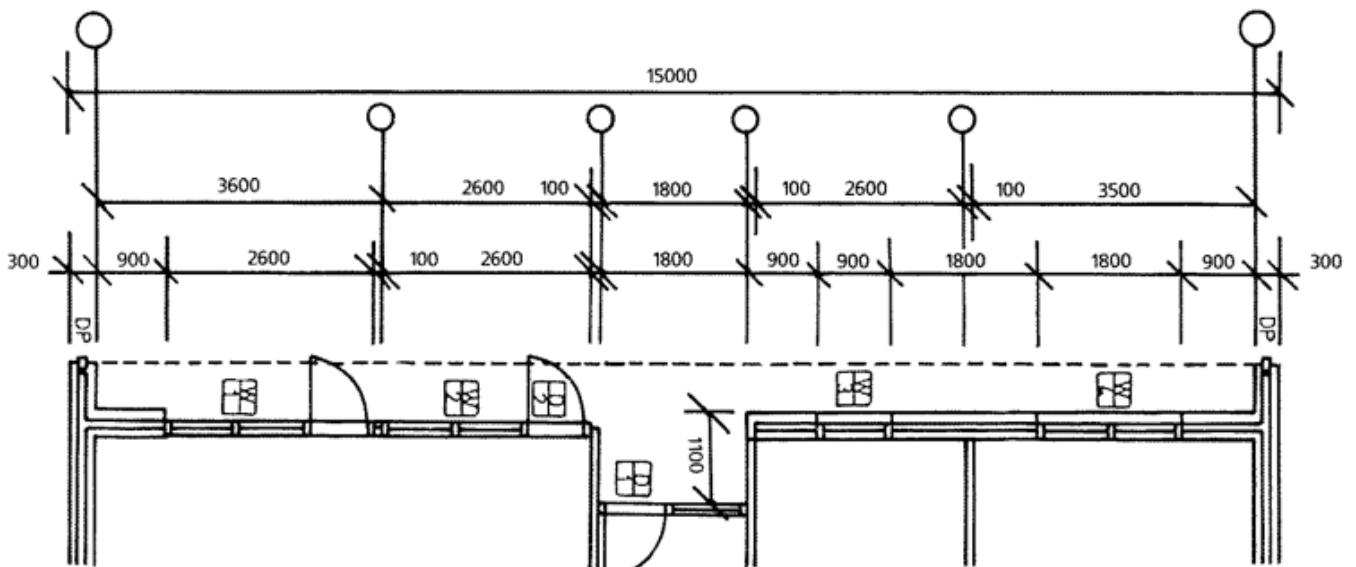

Figure 15 Preferred method of dimensioning drawings using the nominal sizes of openings

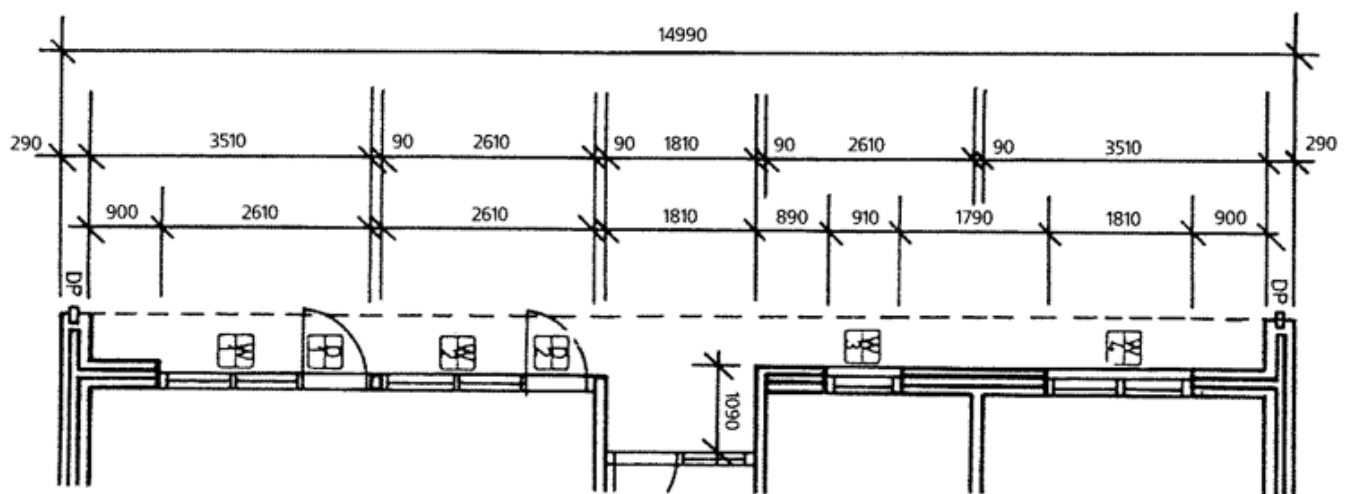
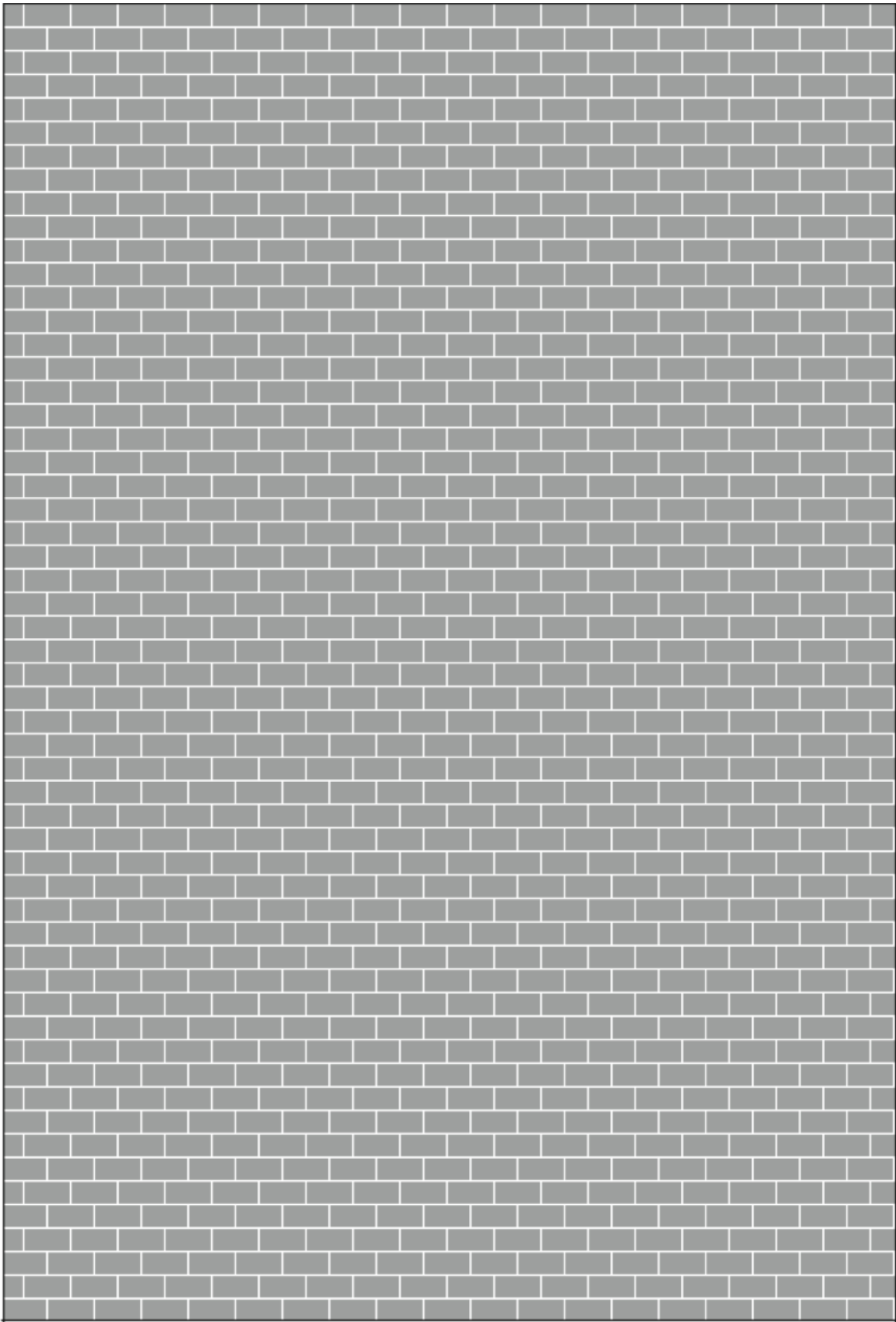
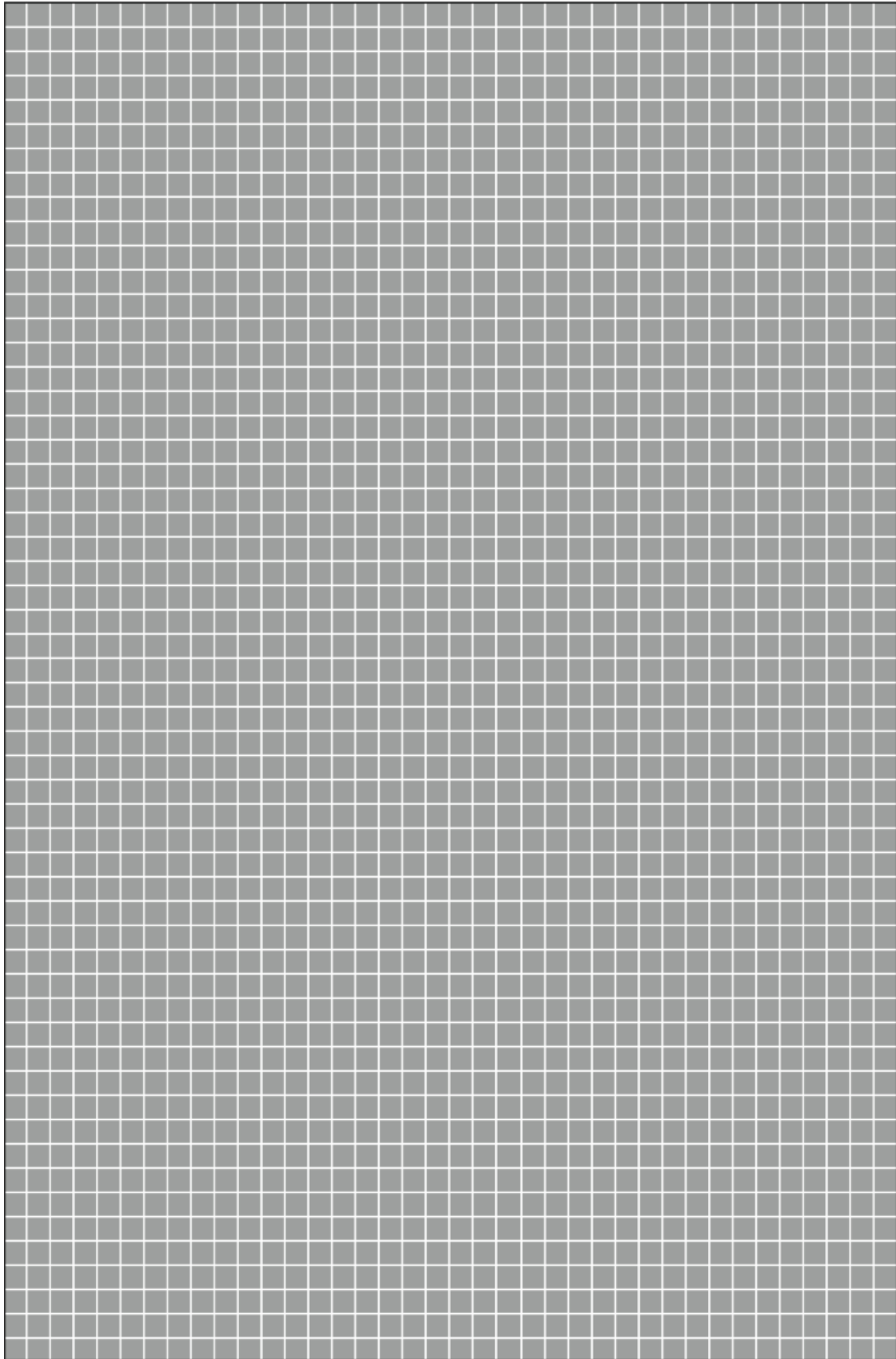

Figure 16 The equivalent actual size of openings



Planning grid showing 200 mm x 400 mm block elevations at approximately 1:50 scale



Planning grid showing 200 mm x 200 mm lock plan at approximately 1:50 scale

7. Estimating Data

Blocks

There are $12\frac{1}{2}$ blocks in every square metre of wall surface area.

Mortar

1m³ of mortar is required for approximately 800 blocks.

For a 1:1:6 mortar mix, the approximate quantities required for 1m³ of mortar are:

6 bags cement

6 bags lime

1.2 m³ of damp sand (allowing 20% bulking)

Grout

Approximate quantities for filling concrete blocks and elements:

Blocks	Required volume (m ³) Per		Number blocks per m ³ of grout
	m ² of wall	100 blocks	
15.01/15.42	0.0054	0.43	220
20.1/20.42	0.083	0.66	150
20.48	0.100	0.80	120
30.48	0.180	1.44	69

Element	Required volume (m ³) per linear m
200 mm wall – isolated core	0.020
200 x 200 mm bond beam (20.20)	0.025
200 x 400 mm lintel	0.042

8. Control Joints

Control Joints are provided in masonry walls in order to prevent cracks appearing. These cracks can be caused by various movements such as:

- Shrinkage of concrete masonry units (or expansion of clay masonry units).
- Temperature movements.
- Differential settlement of footings (**Figure 17**).

Hogging support: top tension cracking and diagonal cracking is likely to occur.

Sagging or dishing support: friction at the base may stop the tension cracking, diagonal cracking still likely to occur.

In unreinforced 90 mm and 110 mm thick walls (including veneer and cavity construction) control joints should be spaced at all points of weakness, and not more than 6 m apart.

In unreinforced walls of 140 mm and 190 mm thickness the inclusion of horizontal bond beams is recommended. In this case the spacing of control joints may be increased up to a maximum of 8 m. The more vertical cores that are filled with grout and reinforcement the greater will be the control of cracking.

Unreinforced Masonry Construction

Control joints should be built into unreinforced concrete masonry at all joints of potential cracking and at the locations shown on the drawings, but in no case greater than 6-m spacing in articulated residential construction and 8-m spacing in other construction.

Reinforced Masonry Construction

Control joints should be built into reinforced concrete masonry at all points of potential cracking and at the locations shown on the drawings. In reinforced masonry walls over 3 m high, the spacing of control joints should not exceed 16 m. In reinforced masonry walls 3 m or less in height, and incorporating a reinforced bond beam at the top, the control joints may be deleted.

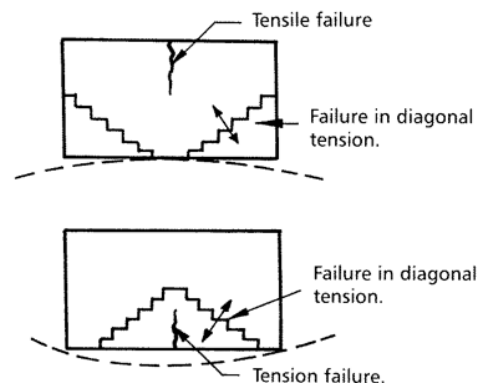
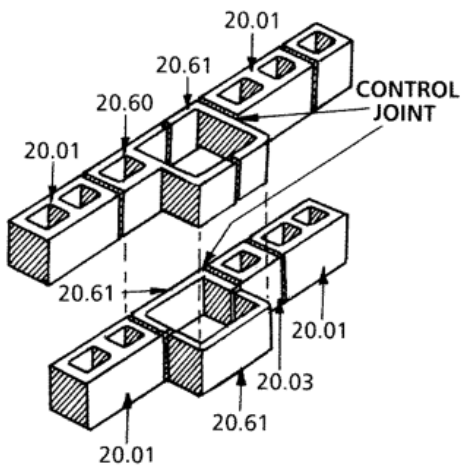

Figure 17 Differential settlement of footings

Control Joints should always be provided at the following locations:

- At major changes in wall height.
- At changes in wall thickness (other than at piers).
- At control joints in floor and roof slabs.
- At T-junctions.

In straight walls, they may be formed with special control joint blocks (20.09 and 20.10), see Figure 19.



This detail relies on the reinforcement in the bond beam to provide the shear transfer across the joint

Figure 18 Typical control joint at a pilaster

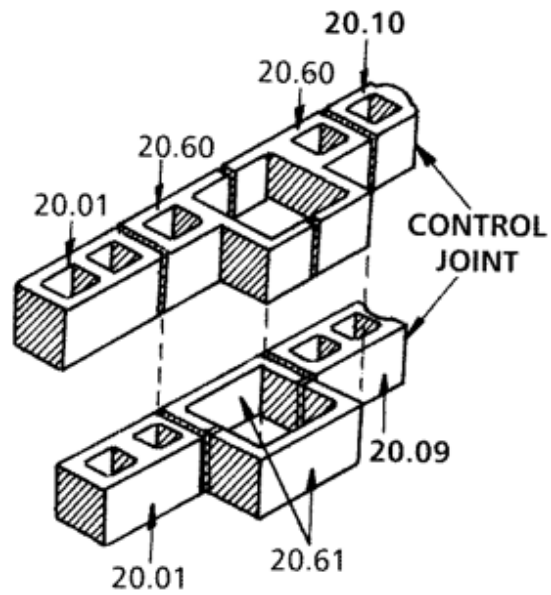

Figure 19 Typical control joint within a wall

9. Articulated Designs (or Panel Construction)

Articulated Masonry Construction – What Is It?

This is the system which eliminates the stress concentrations caused by corners and openings, breaking the masonry by jointing, into separate pieces or panels which allows for relative movement.

The technique of breaking masonry construction into separate rectangles joined by panels which allow relative movement is called “Articulation”. Rectangular panels are vastly stronger than panels with openings and are much less likely to form cracks.

The fundamental principle of articulation is to provide allowances in the form of control joints which allow for anticipated relative movement. Figure 24 shows the way in which an articulated wall would behave when subjected to distortions in supporting members.

The use of articulation is normally confined to unreinforced cavity and veneer construction and does not apply to partially or fully reinforced walls.

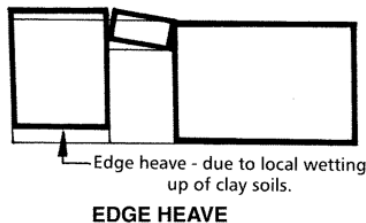
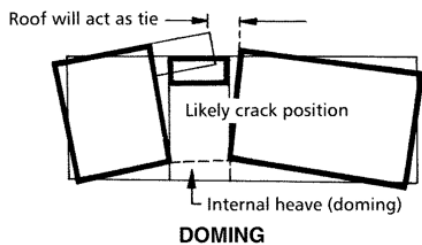
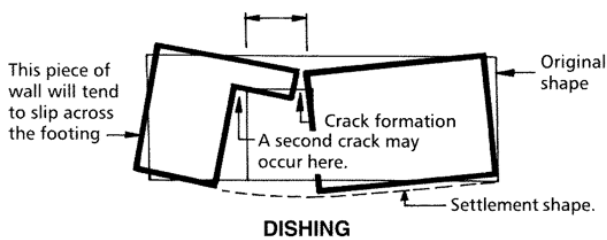

Figure 22 Consequences of distortions of supports of walls with openings

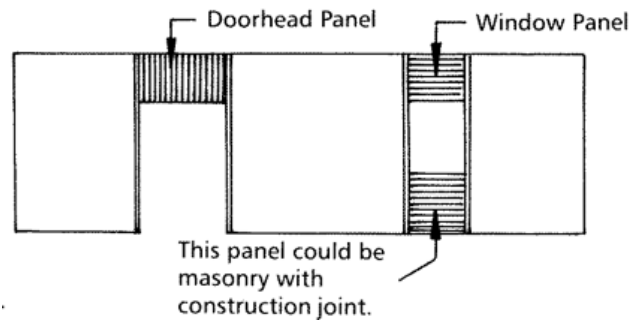

Figure 23 Typical articulated wall

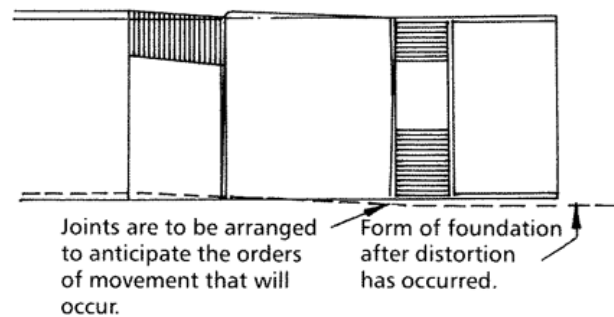

Figure 24 Behaviour of articulated wall after distortion of supporting members

10. Finishes and Treatments of Concrete Masonry Walls

10.1 Finishes to External Walls

External walls may be finished in a variety of ways, including:

- Face blockwork
- Bagging and painting
- Rendering and painting
- Painting
- Textured finishes

Where the wall is to be face blockwork, particular care is required in achieving a high standard of joint finish.

Cavity and Veneer Construction

It is not essential to provide an external finish to these types of walls. Should a more decorative finish be required, there are special blocks that can be used eg, plain or coloured split blocks. Alternatively, a large range of decorative treatments can be used including 100% acrylic-based paint, rolled on texture paint and applied texture treatments.

Control Joints

Surface treatments, other than paint, should not be continued across control joints but should be scribed to allow for movement. These joints must be sealed to prevent water penetration. A typical control joint detail is shown in **Figure 25**.

Joint sealants should be applied towards the end of construction to minimise the effect of panel movement.

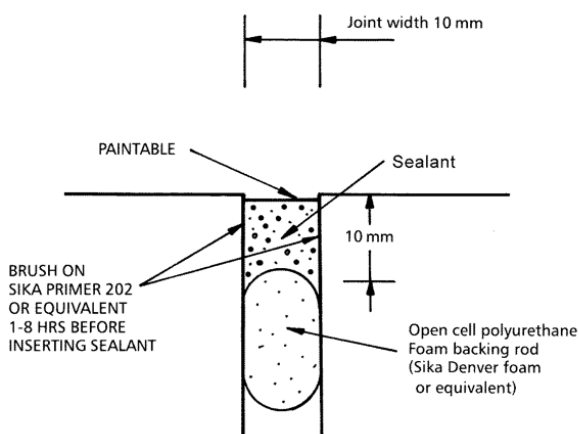

Figure 25 Control joint detail

10.2 Finishes to Internal Walls

Internal walls may be finished in a variety of ways, including:

- Face blockwork
- Bagging and painting
- Adhesive-fixed plasterboard
- Rendering and painting
- Wallpapering
- Painting
- Textured finishes

Where the wall is to be face blockwork, particular care is required in achieving a high standard of joint finish. Surface preparation should be as described in Clause 10.3. When these procedures are followed, an economical and very acceptable finish can be achieved.

10.3 Surface Preparation

Whether or not an external treatment is to be applied to the walls, it is essential that all mortar joints be filled to the depth of the face shells and ironed, the mortar being compressed with an ironing tool slightly larger than the joint, leaving no voids. Particular care is needed to ensure joints under window sills are properly filled. On completion, the external face of the wall should be inspected and any faulty mortar joints or surface defects in blocks should be repaired with a 3:1 sand/cement mixture.

On completion the wall needs to be rubbed down with either a piece of block or carborundum stone to remove any excess material. If the wall is not new, accumulations of dirt, dust, oil or efflorescence must be removed by scrubbing, brushing (with appropriate solvents if necessary) and hosing. Generally, existing paint films must be removed. Check with your paint supplier before applying new paint over old paint.

10.4 Special requirements for Single-leaf masonry System

10.4.1 General

To prevent water penetration, it is essential that single leaf skin walls have a reliable weatherproof finish or treatment applied, the recommended procedures are as follows (see also **Figure 26**):

- Weatherproof all of the external wall, including window reveals, before the windows are fixed (see Clause 10.4.210.4.2).
- Fix windows with Ramset ED642 anchors, or equivalent. Before the anchor is inserted, the hole should be filled with sealant.
- Seal the whole perimeter of the window on the inside and to the head and jambs only of the perimeter on the outside with Sikaflex 15LM or equivalent. The use of sash groove blocks is not recommended.
- Door frames are to be fixed and sealed in accordance with the above, except that the anchors should be Ramset ED655 or equivalent.

10.4.2 Weatherproof Treatments

Application of Paint

Two alternative treatments are recommended:

- Three coats of 100% acrylic-based exterior quality gloss paint (e.g. Wattyl Solagard, Dulux Weathershield, Taubmans All Weather Gloss) applied by brush or roller.
- One complete coat of cement-based paint (e.g. Silasec) followed by two finishing coats of 100% acrylic-based exterior-quality gloss paint, applied by brush or roller.

Whichever of these two treatments is used, it is essential that:

- The manufacturer's instructions are followed, particularly with regard to coverage rate.
- All of the external wall is weatherproofed, including window reveals. This entails fixing meter boxes, down pipes, windows etc, after the paint treatment is complete.

Other Coatings

Alternatively there are other stylish texture finishes incorporating elastic polymers which can enhance the aesthetics of the walls and at the same time providing satisfactory weatherproofing. It is essential that the texture coating incorporates a waterproofing membrane.

Clear Coatings

Clear coatings are not recommended.

11. Applications for Reinforced Blockwork

Reinforced blockwork is used in a great variety of structures. Technical brochures are available from CMAA Member Companies on a number of different applications including Retaining Walls, Housing, Industrial Buildings, Swimming Pools, Fences etc.

Samples of the type of information provided in these brochures include retaining wall construction (**Figure 27**) and single-leaf wall construction system (**Figure 28**).

Single-leaf walling system is used for the construction of most houses in North Queensland and is widely used in Central Queensland. It is a simple system which is suitable for housing in areas of design wind speeds from N2 to C4 in cyclonic and non-cyclonic areas.

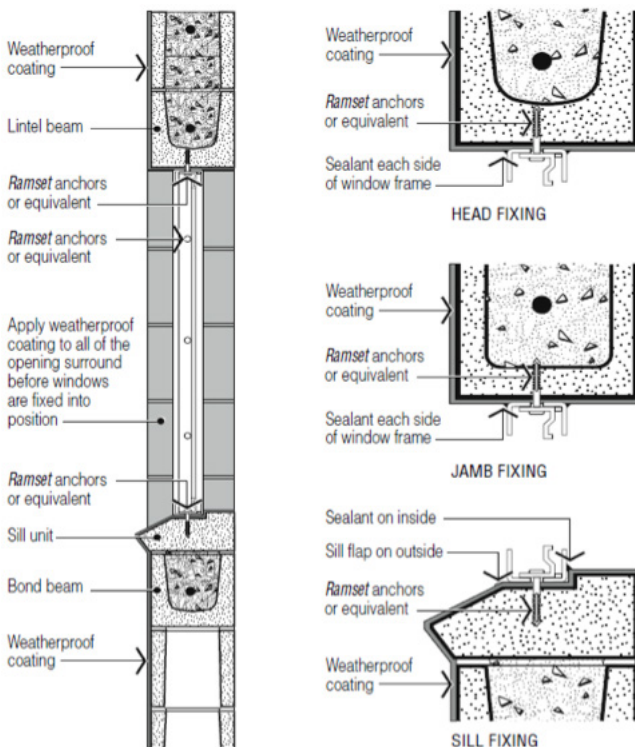

Figure 26 Weatherproofing and fixing of windows in single-skin masonry construction

RECOMMENDED PROCEDURE

1. Weatherproof all of the external wall, including window reveals, before the windows are fixed
2. Fix windows with Ramset ED642 anchors, or equivalent. Before the anchor is inserted, the hole should be filled with sealant
3. Seal the whole perimeter of the window frame on the inside and the jamb and head sections on the outside, with Sikaflex 15LM or equivalent
4. Door frames are to be fixed and sealed as set out for windows, except the anchors should be Ramset ED655 or equivalent.

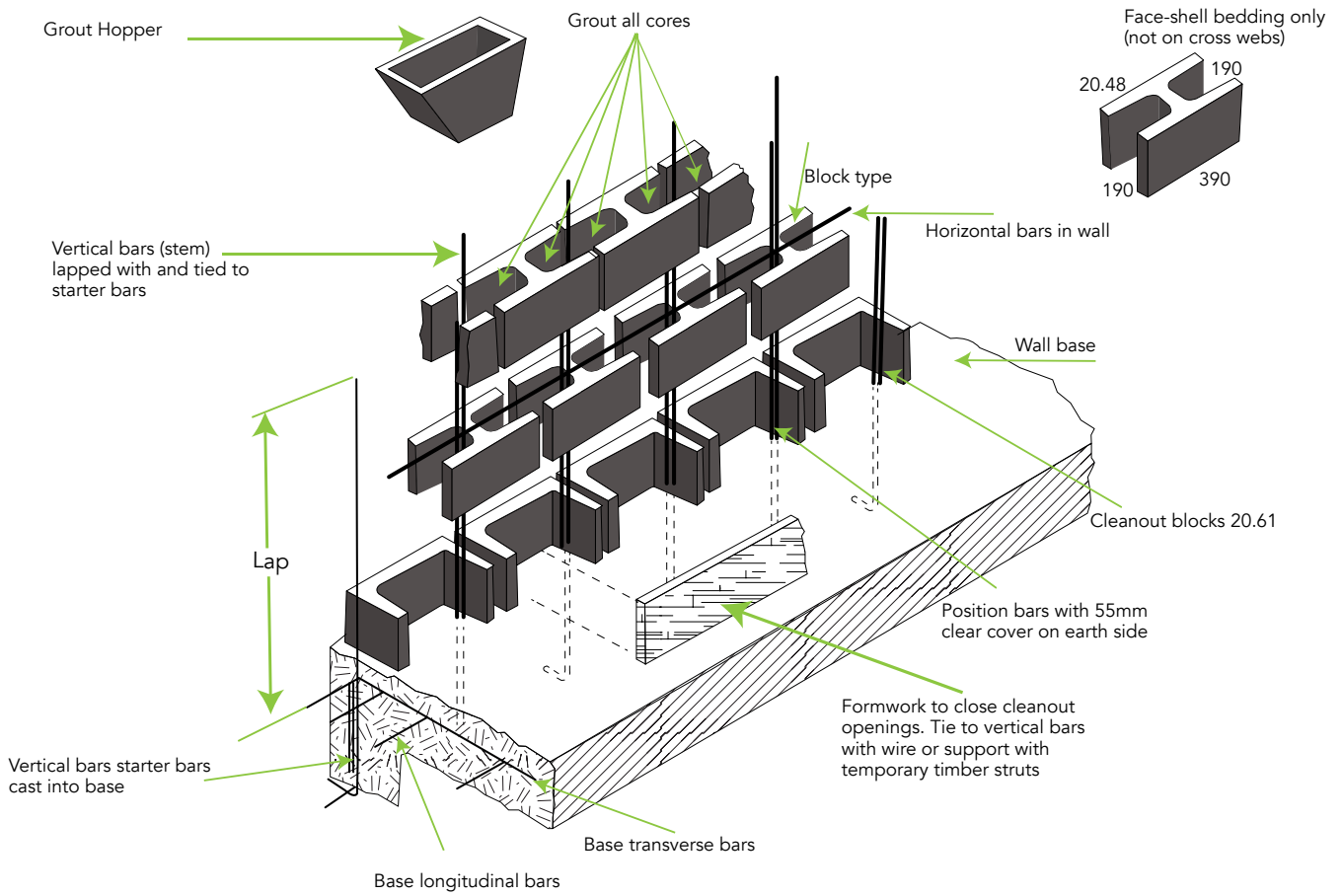

Figure 27 Typical construction details for reinforced blockwork retaining wall

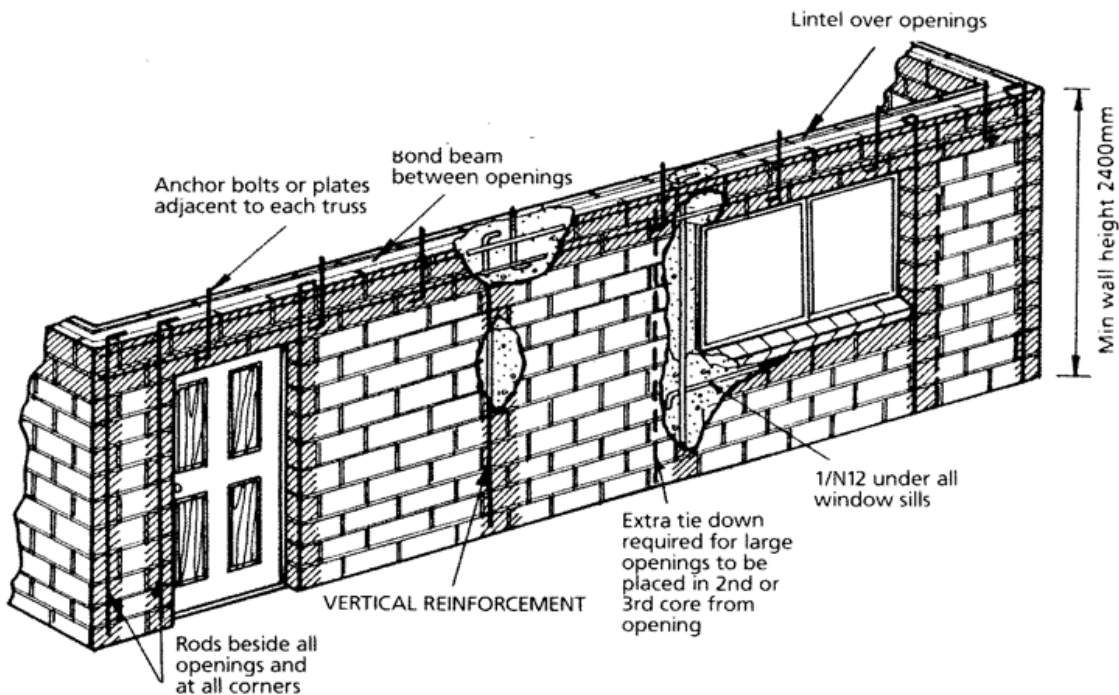

Figure 28 Typical construction details for reinforced single-leaf masonry walling system

12. Grout Filling

12.1 Introduction

The large cores in a block, which make it a hollow unit, have two principal advantages:

- The individual units are lighter to handle.
- The blockwork can be filled with grout.

Grout means highly-workable concrete which can be poured or pumped into small spaces, such as the cores of blocks.

By placing reinforcement in the cores before the grout is placed, the masonry becomes a composite of block, grout and reinforcement which has a strength similar to that of reinforced concrete.

Most masonry walls built out of 150 or 200 series blocks have some parts which are grouted and reinforced, typically a bond beam in the top course and sometimes the end vertical cores.

The cores should not be filled with just a sloppy mortar but with a correctly designed grout to the following specification.

12.2 Grout Specification

The grout used to fill the cores or blockwork walls should be specified as follows:

- Characteristic Compressive Strength minimum 12 MPa, preferably ≥ 20 MPa. There is no limit on high-strength grout to be used.
- Cement content not less than 300 kg/m³.
- Coarse aggregate of 10 mm.
- It should have a pouring consistency which ensures that the cores are completely filled and the reinforcement surrounded by at least an annulus of grout of thickness not less than twice the diameter of the reinforcing bar, completely without segregation of the constituents.

12.3 Grouting

Grout may be mixed on site and poured from buckets into hoppers placed on top of the wall. Alternatively, for larger jobs, the grout may be delivered by transit mixer and pumped into the cores, using a small nozzle on the hose.

Before commencing placement of the grout, it is important that the cores should be clean and free of mortar "dags" projecting into the core. A "clean-out" opening is normally provided so that these "dags" can be knocked off by a steel rod pushed down the core. These are then cleaned out from the bottom of the core before the "clean-out" space is sealed. An alternative method which may be used in some circumstances is to leave a mortar joint unfilled at the bottom of the core and to hose the mortar out of the core before it has set.

In hot weather it may be necessary to hose the cores out with water in order to cool the blocks and so prevent "flash setting" of the grout. If so, this hosing should be completed at least 30 minutes before the grout is placed. Because of the high pressures developed at the bottom of the cores when they are filled, grouting in lifts of more than three metres should not be attempted in one pour. Where the lift is more than 2.4 metres, it is preferable to fill the cores in two stages about 30 minutes apart.

13. The 200 mm Single-Leaf Masonry System – How it Works

Stage 1

Reinforcement in the form of N12 starter bars is either placed and tied prior to pouring, to minimise movement, or placed in the footings immediately after the footing concrete is poured. They are hooked at the bottom to pass under the trench mesh in the bottom of the footing and are long enough to project at least 450 mm above floor level (Figure 29).

They are placed at the building corners, on each side of each door and window opening and at a maximum spacing of 1800 mm* centres between. Their positions are marked on a plan giving distances from the corners for easy setting out.

*Reduction will depend on cyclonic category.

Stage 2

Standard 20.01 blocks are used in the footings up to one course below floor level. 20.20 knock-out blocks are used at floor level with the upper sections of both the webs and the inside face knocked out before laying (Figure 30).

The outer face is left as screed for the floor slab and the cores of the footing wall blocks are filled with concrete when the slab is poured. Provided the wall is not more than 3-courses high, only the reinforced cores need to be grouted.

All plumbing in the slab and/or the external wall is located accurately before the concrete is poured.

Starter bars are cast into the floor slab to align with the cores of reinforced bracing walls where these are required.

Stage 3

If metal door frames are used, they will be stood in position so they can be built into the wall as the blocklaying progresses.

When the first course above the floor level is laid a cleanout block is used wherever there is a starter bar so that mortar droppings can be removed on completion of the wall (Figure 31). 20.01 blocks are used elsewhere (10.01 or 15.01 for internal walls) but with 20.12 lintel blocks above window and door openings. 20.20* knock-out blocks are used at the ends of each lintel and for the whole of the top course of the external wall. The cores of the knock out blocks are sealed where no vertical reinforcement is located and which are not over a lintel.

*or 20.28 where available.

Two N12 bars are placed horizontally (in the lintel blocks) above each opening and all around the top course (Figure 32). One N12 bar is placed in the top course of all reinforced bracing walls. A N12 bar is dropped into every core where there is a starter bar. These are then bent back and tied to the horizontal reinforcement in the top course.

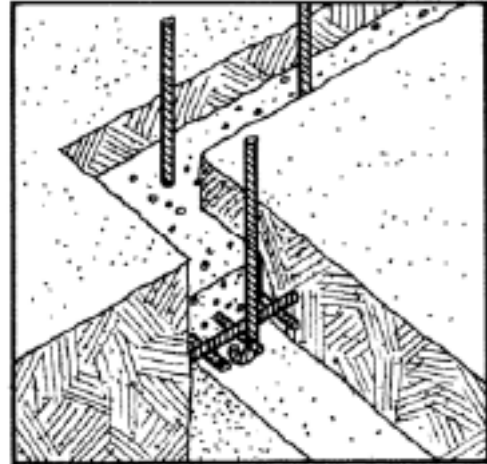

Figure 29

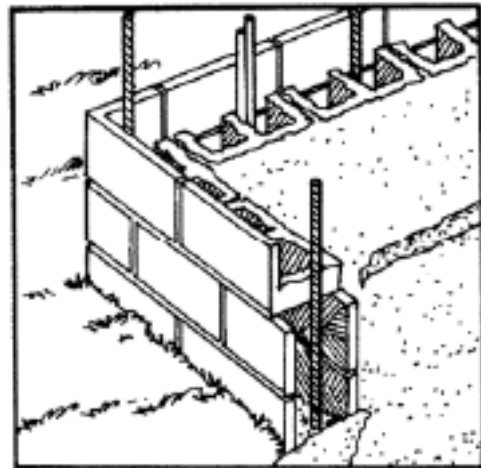

Figure 30

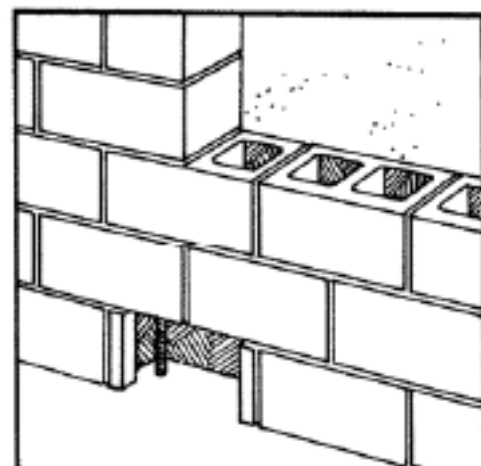

Figure 31

Stage 4

Before the lintels and cores are filled, the electrician locates all switches, socket outlets, etc., punches a hole in the face shell to accept the switch box or outlet box and places a short piece of conduit vertically through the bond beam at the top of wall above each core which is to take wiring. The plumber installs any pipework which is built into the cores of the walls.

Threaded rods placed in the wall at 900 mm centres projecting to above truss height and on the centre line of the wall. These are used to fix the top plate and trusses down (Figure 33). They are bent and hooked under the bars in the bond beam (Figure 32). Alternatively, steel plates are used where no top plate is required (Figure 34).

When the preparations are complete the concrete grout is pumped into the bond beam on top of the walls or in the second course where lintels occur filling only those vertical cores which have reinforcement. It takes about two hours to complete the pumping of concrete grout into the walls of an average house, including setting-up and dismantling time. When ordering grout it is important to specify that it is for filling concrete blocks, Block Fill is the common industry terminology. (Refer to 7 Estimating Data).

Whilst the grout in the bond beams is still workable, ensure the hold-down plate is beside the crayon mark on the top of the wall at 90° to the top of the block.

Stage 5

The top plate is drilled and fixed to the wall by nuts and washers on the threaded rods which have been cast in. The roof trusses are fixed to the top plate with plate connectors. A cyclone batten is placed over the trusses and drilled to fit over the threaded rods. Nuts and washers are then used to tie the cyclone batten down (Figure 33).

Note: Alternative methods are available. In particular, where the blockwork is over 2400 mm high and no top plate therefore required, steel plates are cast on the top of the wall. A hole is drilled through the gang nail cleat on the truss to align with the hole in the plate and the two are connected by a bolt (Figure 34).

Before the ceiling is fixed, the electrical carcass is placed in position, the wires in the walls passing down through the plastic conduits (refer Stage 4) and hooked out of the holes previously formed. Switch and socket boxes are fixed directly to the face of the block wall, using toggle bolts or Rawlplugs, depending on whether the fixing is in the face of the hollow section or into the solid part of the block.

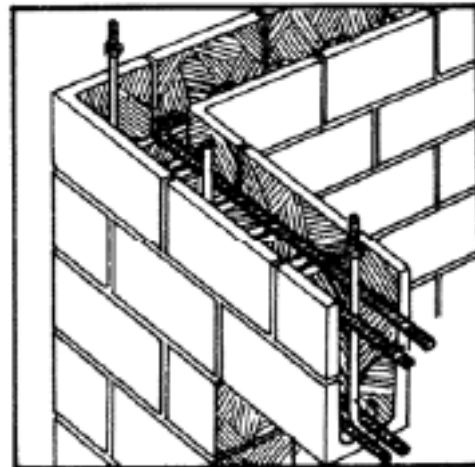

Figure 32

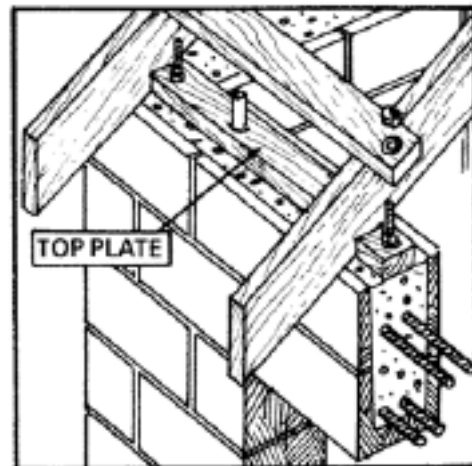

Figure 33

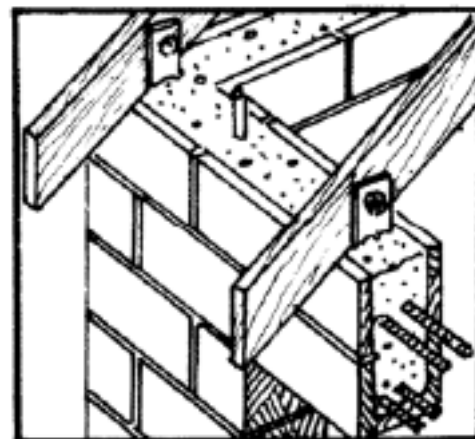

Figure 34

Stage 6

Windows and aluminium sliding glass door frames are then fixed directly to the block jambs and lintels and sealed all round with an exterior-grade sealing compound. All walls should then be wellrubbed down with a piece of masonry and brushed to remove mortar protrusions and dust. External faces are then treated to ensure a completely weatherproof finish, as detailed in Clause 10.4.2. (There are many alternatives, but Tyrolean and various forms of stucco are popular.) Whatever external treatment is applied, it is necessary to apply a weatherproof finish to the wall below floor slab level down to below ground level. Frequently this area is rendered and painted a different colour.

To provide greater variety of style, particularly where a spanish effect is sought, arches of various shapes are formed with plywood form work and poured up to the level of the under-side of the bond team before the latter is laid or 10.04 blocks are used in a soldier course and 20.01s are saw-cut to match (Figure 35).

The internal walls may simply be painted after rubbing down. As an alternative, the joints may be flushed, the surface lightly bagged and a heavy paper applied preparatory to wallpapering. The surfaces may also be plastered or plaster board may be fixed in accordance with manufacturers' instructions (see Clause 10.2).

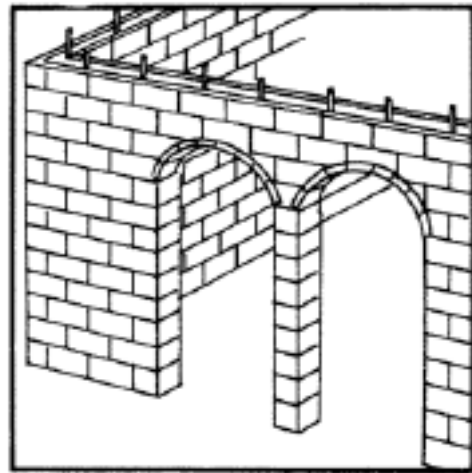

Figure 35

14. Single-Leaf Masonry Estimating Worksheet

--	--

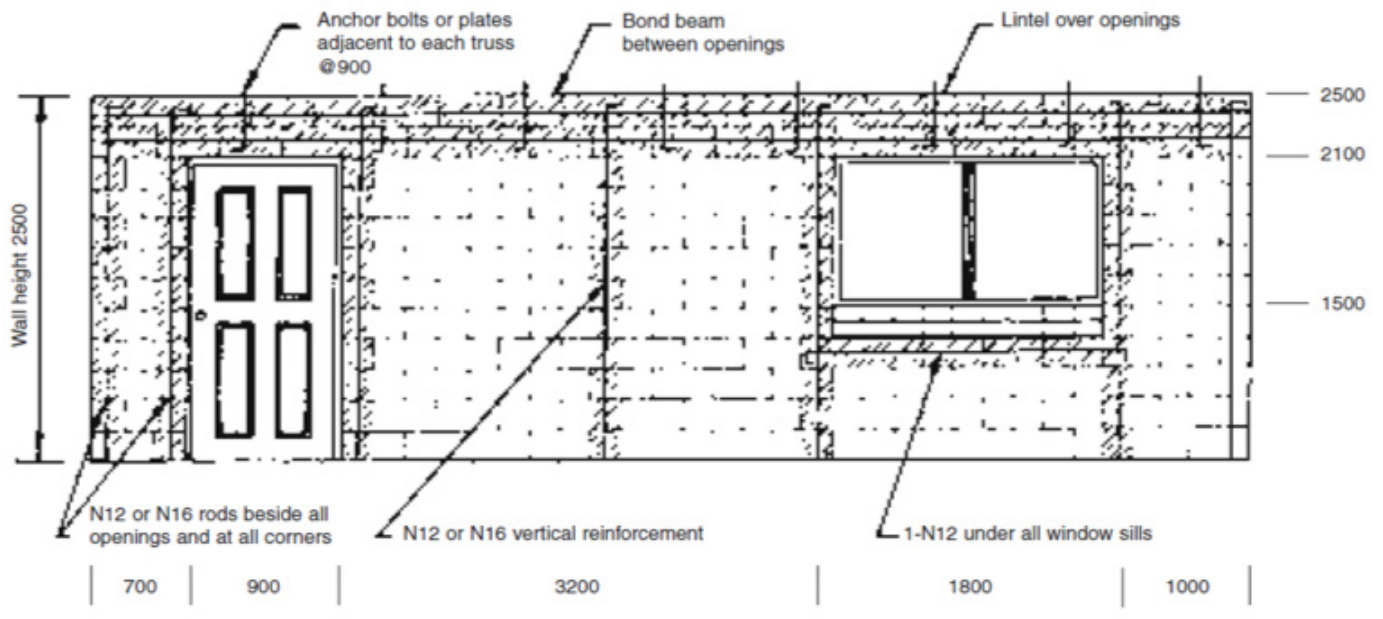
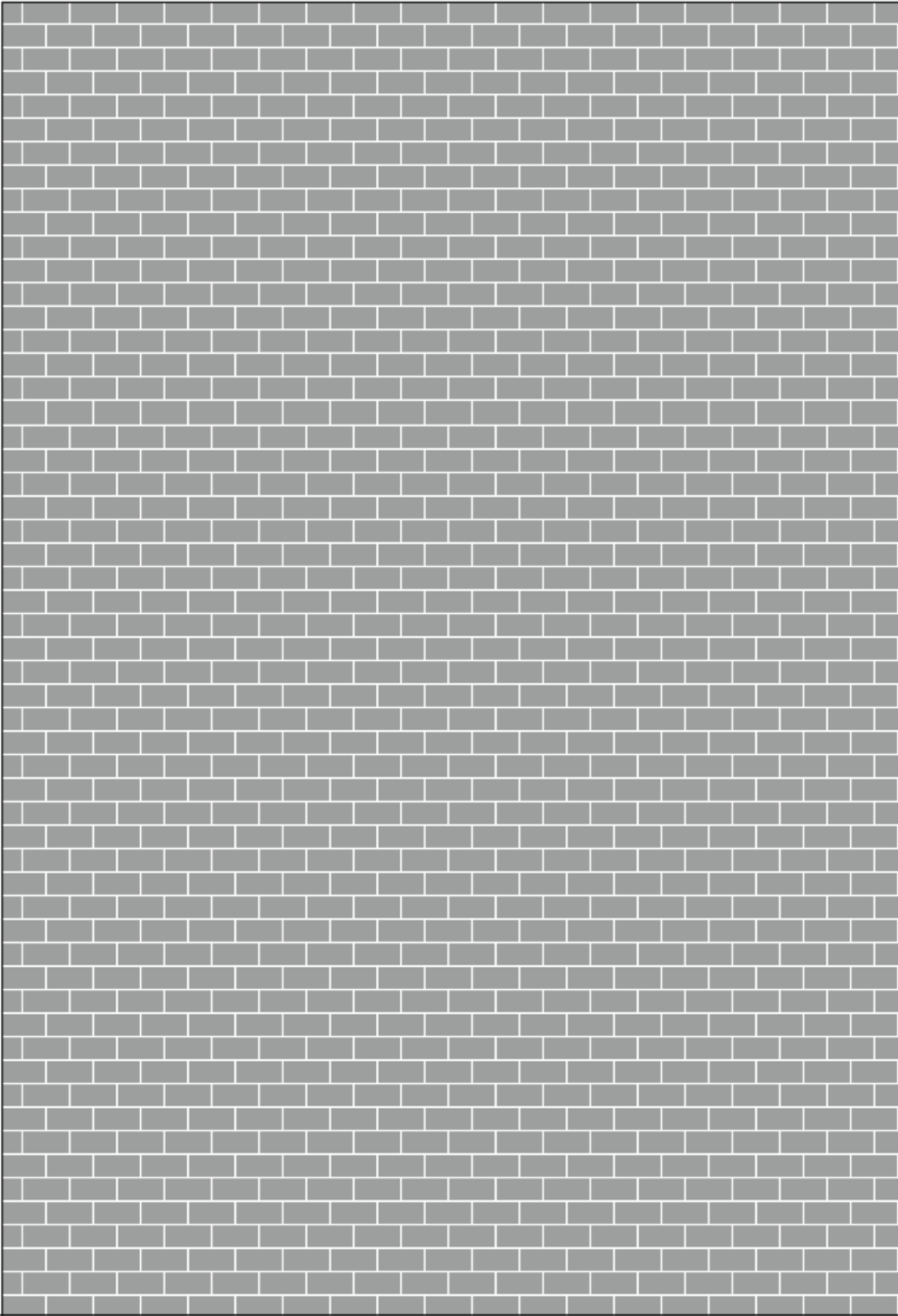

Figure 36 Typical single-leaf masonry details



Planning grid showing 200 mm x 400 mm block elevations at approximately 1:50 scale

15. Cleaning of Masonry

15.1 Good Practice

Professional cleaners are the recommended option.

If professional cleaners are not being used the first question to be asked is what stains am I trying to remove and is the use of a chemical necessary.

Select a small test area and always start off with the weakest solution of chemicals in most cases this will be 10 parts water to one part chemical.

Always follow chemical and product manufacturer directions.

CAUTION. High-pressure water cleaning may damage masonry. Use with caution and only with experience operators.

Safety Precautions

- Care must be taken to avoid damage to adjacent materials.
- To avoid personal injury wear protective clothing.
- Always pour chemicals into water.
- Obtain a copy of any Material Safety Data Sheet available from the relevant chemical supplier for reference.

15.2 Mortar Smears

Mortar smears should be cleaned off before they set. If this does not occur one of the following treatments will be necessary.

- Mortar dags should be removed by rubbing with a piece of the brick or block.
- Water and a stiff-bristle brush will remove most mortar stains after initial mortar cure (12 hours in normal conditions).
- Proprietary chemicals that will remove stubborn mortar stains are: TR50, ANTI EFF.

15.3 Stains

For general stains, oxalic acid is an effective cleaning agent and has the benefit of not attacking the masonry itself.

15.4 Iron Oxide Stains

These stains are frequently caused by the incorrect use of hydrochloric acid

The so-called rust stain can be a reaction between the acid and the iron oxides in the masonry products and/or the mortar sand.

Light to medium iron oxide stains may be removed by the use of phosphoric acid. A solution of one part acid to four parts water is applied to the dry wall and allowed to stand until the stain disappears. This is usually about 30 minutes.

The acid is then neutralized with a solution of 20 g to 40 g bicarbonate of soda in one litre of water. This solution should be left to remain on the product.

Note: Phosphoric acid can fade products colored with metal oxides.

15.5 Hardwood Timber

These may be removed by the liberal application of strong household bleach (a chlorine generator) onto dry surface. Re-apply as necessary.

15.6 Softwood Timber

A solution of 250 grams of oxalic acid dissolved in 4 litres of hot water should be applied liberally to dry surface using a soft brush, allowed to soak for 1 hour and then washed off. Repeat as necessary

15.7 Clay or Loam Stains

These may be removed with a solution of 50 ml household detergent, plus 500 grams of oxalic acid dissolved in 4 litres of warm water. Lightly wet and apply the solution with a stiff nylon brush. Wash off and repeat as necessary.

Using washed pit sand in the mortar mix will reduce staining of this kind.

15.8 Mosses, Moulds and Lichens

These appear either as black stain or like a green carpet. Algae will appear as a green area often with a hair-like growth, around taps, gutter overflow areas, etc.

Apply a strong solution of a chlorine generator (swimming pool chlorine or strong household bleach) to the surface. Agitating with a stiff brush will speed up the removal. Leave 24 hours and repeat as necessary.

15.9 Efflorescence

The term efflorescence or new bloom is given to a powdery deposit that forms on the surfaces of porous building materials such as masonry units, mortar and concrete. The temporary appearance of efflorescence is common on new masonry. It is essential to first dry brush or scrub loose salt from the wall – do not hose as water will only put most of the salt back into the wall (this may cause future problems). The salts that appear as efflorescence can enter the wall from various sources. The masonry units, cement or sand may all contain salts, the atmosphere may carry sea spray in coastal areas, or sulphur acids in industrial areas. Saltbearing ground waters or garden fertilizers may be drawn into masonry below the damp-proof course. If damp-proof courses are faulty, salts from ground waters may pass into higher levels of the wall. Efflorescence on new masonry may be unsightly, but it will not usually cause damage unless it persists for a long time. Persistent efflorescence may be a warning that water is entering the wall

through faulty copings, flashings or pipes.

For efflorescence to occur, three conditions must be present:

- There must be salts present.
- There must be water entering the masonry
- The masonry must be able to dry out. The absence of any of the above three conditions will prevent efflorescence. Any situation that allows water to enter the wall is likely to promote efflorescence. The most common causes are:
 - Ineffective copings and flashings.
 - Excessively-raked joints, which allow water to enter the bed face of the masonry (half round ironed joints are the preferred finish for all masonry).
 - The use of air-entraining agents in the mortar, which makes the mortar, act like a sponge.
 - Unsuitable protection of masonry units on site. Before units are placed in the wall they can absorb ground salts and excessive water in the stockpiled masonry and can mobilise latent salts if they are present in the masonry.

It is desirable to store masonry off the ground and loosely-covered with a waterproof membrane. Efflorescence should be removed with a stiff brush. Good laying practice and site procedures are the best guarantee for keeping job efflorescence-free.

15.10 Calcium Carbonate (heavy deposits)

Can be caused by hosing efflorescence, the incorrect use of hydrochloric acid, not enough pre-wetting with chemical cleaning and not correctly neutralising chemicals used in the cleaning process. It appears as a white film on the masonry.

Apply full strength to the stained product and allow to stand for about five minutes. Apply more chemicals scrub vigorously and wash off thoroughly.

The acid is then neutralized with a solution of 20 g to 40 g bicarbonate of soda in one litre of water. This solution should be left to remain on the product.

Note: General success with these methods has been had in controlled cleaning trials. As site conditions, and products may vary, it is the responsibility of the user to obtain information on the product to be used and verify the suitability of the product for this procedure and the intended application.

15.11 Hydrochloric Acid

Also known as *spirit of salts* and *muratic acid*.

These acids are extremely corrosive and their use is not generally recommended for the cleaning of concrete masonry. If they are used for whatever reason, ensure the following procedure is adhered to:

- Saturate with clean water all areas (unless otherwise stated) to be cleaned as well as the masonry below to the extent that the suction of the masonry product is exhausted.
- Apply a solution with the ratio of 1 part acid and 10 parts water to the wet surface with a stiff brush, vigorously scrubbing the affected area.
- Allow a standing time of 1–2 minutes. Do not allow to dry out. Keep it moist throughout the cleansing process.
- Flush the treated surface thoroughly with water, to neutralize the acid whilst again scrubbing with a stiff brush. Allow the surface to dry.
- If the affected area is not completely cleaned, repeat the above steps (strength to suit the application).
- If acid salts (white bloom) are left on the surface, repeat the process with a weak dilution and ensure the whole surface is vigorously scrubbed whilst applying the agent and flushing off with water.

The acid is then neutralized with a solution of 20 g to 40 g bicarbonate of soda in one litre of water. This solution should be left to remain on the product.

16. Australian Standards and Building Code of Australia

All design and construction should be in accordance with the relevant Australian Standards and the Building Code of Australia Volumes 1 or 2, as appropriate. The relevant Australian Standards are:

AS 4773.1 Masonry in small buildings-Design

AS 4773.2 Masonry in small buildings-Construction

AS 3700 Masonry structures

PO Box 275, St Leonards NSW 1590 Australia
Suite 7.01, Level 7, 154 Pacific Highway, St Leonards NSW 2065 Australia
Telephone +61 2 8448 5500
Technical hotline 1300 667 617
ABN 30003873309
www.cmaa.com.au

