



**OUTBACK
SLEEPERS
AUSTRALIA**

Adding distinction to your landscape design



OUTBACK SLEEPERS **AUSTRALIA**

**Concrete Sleeper Specialists
for Retaining Walls**

Outback Sleepers Australia.



Our Experience Shows

We have been making concrete sleepers for over 20 years and have manufactured over 3 million of them. No wonder we are so good at what we do.

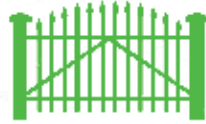

A Product For Every Project

It does not matter what type of retaining wall you need. We promise to have a style that will suit your landscape project and help bring beauty and value to your home.



Superior Strength Concrete

The stronger the concrete, the more durable your retaining wall. With decades of experience, we manufacture the strongest concrete sleepers in the industry.



Exceptional Sales Service

When it comes to helping you with your landscaping project, we know our products inside and out. So for friendly advice and fast order turn around – call us today.

Your Local Specialists for Concrete Sleepers.

Strength and durability are our absolute priority.

The construction of one or more retaining walls will be an essential part of a new home or garden landscape. It is often one of the first projects undertaken and one of the costliest and hardest to fix if not done correctly the first time. For this reason, your retaining wall must last as long as possible.

Concrete Sleepers are the perfect retaining wall building material. The strength of concrete allows you to build higher walls, and they will never rot or be affected by pests. These characteristics make them the ideal zero maintenance solution.

Concrete retaining walls are easy to install and perfect for levelling sloped land, minimising erosion, creating feature garden walls or simply building several veggie patches.

**Add Value,
Space and
Style to
your Garden.**



Strongest on the market.



Our Sleepers.

What Makes Our Concrete Sleepers Better Than The Rest?

We believe in quality manufacturing at every stage. Outback Sleepers Australia (OSA) recognised from the beginning the importance of continually improving to ensure our products match the requirements of home builders and landscapers (in Australia).

Our modern manufacturing techniques allow us to provide customers with sleepers that use industry-leading **60MPa** concrete. They easily surpass the Australian standard and the strength of our competitors' products, **making them the strongest retaining wall concrete sleepers on the market.**

We use the latest manufacturing technology and continuously improve our methods, allowing us to provide customers with sleepers of the highest quality.

Our sleepers are certified by a **Structural Engineer** to have a **50-year lifespan**, ensuring that they will be the only ones you'll ever need.

So when it comes to building a retaining wall **don't take chances on the quality of your concrete sleepers** – it could end up being a very costly mistake. Talk to one of our helpful sales staff and let us add distinction to your landscape design.

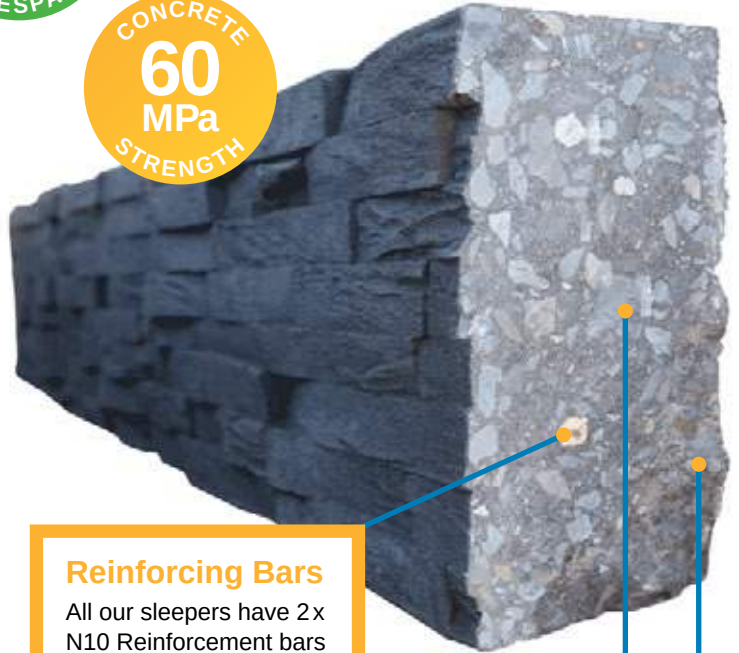

Reinforcing Bars

All our sleepers have 2x N10 Reinforcement bars throughout the sleepers.

*Cribs have 1 x N10 Reinforcement bar

50 Year Product Lifespan

We manufacture our sleepers to the Australian standard AS3600/2018, which means that our sleepers are designed for a 50-year product lifespan.

Exceptional Strength

Industry leading concrete strength of 60MPa.

*50% stronger than 40MPa concrete (based on equivalent dimensions).



2m Products:

Standard (STD)
2m x 200mm x 80mm

Heavy Duty (HD)
2m x 200mm x 100mm

Extra Heavy Duty (EHD)
2m x 200mm x 120mm



The only limit is your imagination.

Our versatile and attractive products will complement any garden design – from zen garden landscaping to the classic Australian home.



Quality Assured.

There's A Product For Every Project.

Our business was initially established to cater to the growing market for retaining walls in Adelaide, beginning with the idea of adding colours and patterns to concrete sleepers. The aim was to create a modern and desirable sleeper to help people with their building and landscaping projects.

OSA offer a wide range of colours and designs, giving you complete creative freedom. From the classic 'Cove' to our flagship 'Kensington' sleeper, we will have a style that suits your landscape and will bring beauty and value to your home.

Exceptional Service. Fast Order Turnaround.

Outback Sleepers proudly manufacture all our products at our Lonsdale factory with the state-of-the-art facility providing consistent high quality products.

We pride ourselves on having extensive production capabilities, which allows us to provide a quick turnaround time from date of order to delivery. We will help ensure your landscaping project remains on schedule.

Our friendly staff are only a call away to discuss your design requirements and provide expert advice. We can organise the delivery of concrete sleepers as well as all the retaining wall steel required to finish your project perfectly.

Our Quality Separates Us from the Competition.



Our Products.

Concrete Sleepers

2m Sleepers.

Standard (STD) 2m

- 2000 x 200mm x 80mm
- 2 x N10 Reinforcement Bars
- Build up to 2m high

Heavy Duty (HD) 2m

- 2000 x 200mm x 100mm
- 2 x N10 Reinforcement Bars
- Build up to 3m high

Extra Heavy Duty (EHD) 2m

- 2000 x 200mm x 120mm
- 2 x N10 Reinforcement Bars
- Build up to 4m high

2.35m Sleepers.

Heavy Duty (HD) 2.35m

- 2350 x 200mm x 100mm
- 2 x N10 Reinforcement Bars
- Build up to 2.4m high
- Available in Lonsdale and Blackwood only.

Cribs.

2m or 2.4m Crib

- 2000 x 100mm x 100mm or 2400 x 100mm x 100mm
- 1 x N10 Reinforcement Bars

2.4m Sleepers.

Heavy Duty (HD) 2.4m

- 2400 x 200mm x 100mm
- 2 x N10 Reinforcement Bars
- Build up to 2.4m high

Extra Heavy Duty (EHD) 2.4m

- 2400 x 200mm x 130mm
- 2 x N10 Reinforcement Bars
- Build up to 2m high



Kensington.

Actual sleeper product colours may vary to images in this brochure.

A close-up photograph of dark grey, textured stone blocks. A white rectangular border is overlaid on the top left, containing the text 'McLaren.' in white font with a small orange dot at the end of the period.

McLaren.

A close-up photograph of light tan, textured stone blocks. A white rectangular border is overlaid on the top left, containing the text 'Cove.' in white font with a small orange dot at the end of the period.

Cove.



Actual sleeper product colours may vary to images in this brochure.



Blackwood.



Lonsdale.



Actual sleeper product colours may vary to images in this brochure.

Our Products.

Under Fence Plinth

Prolong the Life of Your Fence. Gain Privacy. Fill the Gap.

Blackwood.

Lonsdale.

**The only engineered
concrete Under Fence
Plinths on the market!**

If you are installing a fence, then our Under Fence Plinths (UFP's) can improve both the fence's appearance and durability. Under Fence Plinths prolong the life of your fence by preventing the fence panel from sitting in the dirt and rusting. UFP's also fill the gap underneath boundary fences and provide extra privacy for your property.

Our Under Fence Plinth's are **designed** and **engineered** to be used for a maximum height of 400mm (or two UFP's high). We stress that UFP's are not designed or suitable for retaining purposes – they are specifically made to prolong the life of your fence, fill the gap underneath fences and provide extra privacy (gain extra height).

Under Fence Plinth

- 2340 x 200 x 50mm **UFP STD**
- 2340 x 100 x 50mm **UFP CRIB**
- 2355 x 200 x 65-50mm **UFP HD**



Our Products.

Step Kits

Step Kits for Retaining Walls.

Our Concrete Step Kits are the perfect way to finish off your retaining wall and improve its functionality with easy access to different levels in your garden. They are produced as a kit and come in size options of 2m and 2.4m width to ensure they will match your landscape project requirements.

We produce our steps kits to match all of our concrete sleepers: Cove, Kensington, McLaren, Blackwood and Lonsdale; allowing you to perfectly finish off your retaining wall with steps that will not only match but have the same level of quality and strength.

One layer is 200mm high, this includes 2 x sides, 2 x treads and a crib (the crib will match the pattern of the sleeper), they are the same height as a sleeper and same colours that the sleepers are available in (Grey, Charcoal and Sandstone).

They are available as a kit that starts at 1 step high (200mm high) up to 6 steps high (1.2m high).

If you require higher steps you can increase the step height from 1.2m by using another step kit to make the heights you require, this will require extra step treads to continue the step landing.

Step Kit includes per layer:

2 x Sides, 2 x Treads, 1 x Crib,
2 x Plates and 4 x Pins.

Side: 2000 x 200mm x 100mm

Tread: 2000 x 200mm x 100mm
2400 x 200mm x 100mm

Crib: 2000 x 100mm x 100mm
2400 x 100mm x 100mm

Please note: Chemical Anchor sold separately.



Our Products.

Steel + Sleeper Lifter

Steel for Retaining Walls.

Get your retaining wall steel delivered with your sleepers and save time and money. We don't charge extra for delivering your steel. Most importantly, we will ensure that you receive high-quality steel posts and, the correct steel type* required for your retaining wall.

We offer Galvanised and Primed (Red) steel posts and can supply any size and type of steel required for your project. Generally, this will be for walls that are designed by an engineer, with the size and type of steel required stated on the walls technical specifications. For more information, please contact our Sales team for assistance on (08) 8387 9227.

Minimum Steel Sizes:

I Beam: 120 UB 65

C Channel: 125 x 65

*Please note that we don't recommend 100 x 45 Steel for our products.

Galvanised.



Primed.



Sleeper Lifters for Easy Installation of Sleepers.



Save time and your back by lifting our sleepers safely. Sleeper Lifter can be used with a bobcat, dingo or excavator, allowing the sleepers to be put in place without straining yourself. Suitable for installing sleepers in walls of any height.

Australian Designed and Manufactured. Certified testing number NAS4599. Rated for up to 300kg.

- This mechanical retaining wall Sleeper Lifter comes equipped with a lifting eye, which can be attached to any bobcat, excavator, crane, dingo or backhoe.
- Australian designed, engineered and manufactured with a maximum opening width of 140mm and a safe working load of 300kg.
- Fitted with polyurethane blocks that do not mark the concrete sleepers.

Specifications

- Grip range: 10-140mm
- Workload: 300kg
- Light-weight clamp: 21kg
- Dimensions: 540 x 390 x 180mm
- Manual lock for easy release
- Long lasting polyurethane pads
- Replacement polyurethane pads available
- Certified testing number #NAS4599.

Installation Guide.

Concrete Sleepers



1. Hole centre.

- Set pegs at each end of the retaining wall site and connect with a string line to give the required alignment.
- Holes should be dug at 2010mm centres for 2.0m sleepers and 2410mm for 2.4m sleepers (Note: a similar allowance of 10mm can be used for other lengths).
- Hole diameter must be at least 450mm for a one metre high retaining wall.

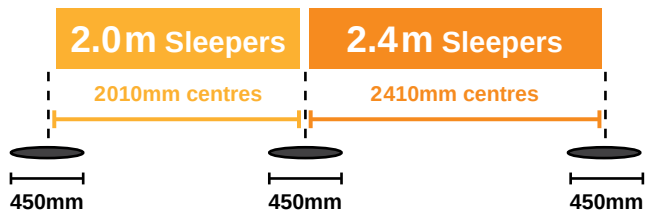

2. Post holes.

- For a one metre wall, the post holes must be dug 1100mm deep.
- After ensuring that the post tops are the same height, place steel in the hole and concrete.

Note: DO NOT OVERFILL HOLES.

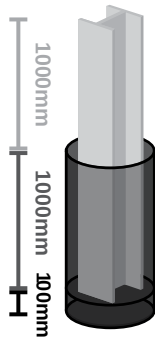

3. String line.

- With the string line still in place, check the alignment of all posts with a spirit level.
- Re-check distances between posts. This can be done with a tape measure or a piece of cord cut at 2010mm or 2410mm.



4. Sleepers.

- Ensure concrete has cured overnight.
- Place first sleeper between posts, then proceed to check the measurement from the top of the sleeper to the top of each post.
- Use fibro-cement sheeting for packaging under the bottom of the sleeper to adjust height, then install the rest of the sleepers.
- Check the measurements from the top of the post to sleeper as you go.

Note wedge/packers: It's good practice to make wedges from scrap timber to ensure sleepers are held against the front of the post.

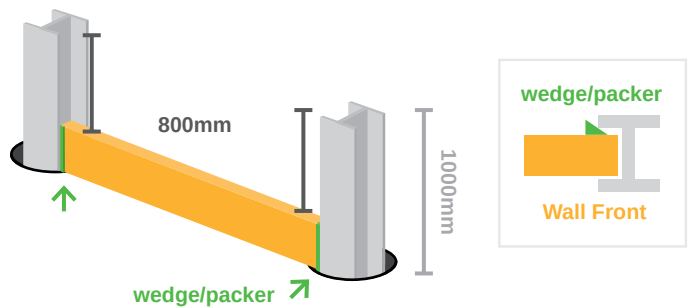

5. Drainage.

- Once sleepers have been installed, place a plastic membrane (Forticon) behind the wall and AG pipe or strip drain at bottom (back) of the wall. (See diagram)
- Cover the pipe with 20mm gravel for drainage.

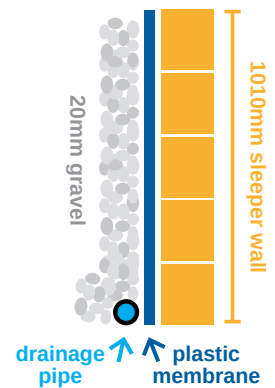

Please check with your local council before constructing any retaining wall as council approval and Engineering advice may be required.

Note: Please ensure that during installation no equipment is to be driven over the backfill within 75% of the wall height. Compaction, if any, within this area should be with non-vibrating hand equipment, weighing no more than 500kg per square metre of footprint. If greater compaction is required, please obtain engineering advice. Wall designs shown are for 'typical' soil conditions. For walls over 1 metre, you should seek independent engineering advice based on your specific site conditions.

Installation Guide.

Under Fence Plinth



- Retain the life of your fence and fill the gap underneath your 'Panel Fence' or 'Post and Rail Fence' by using an UFP from *Outback Sleepers Australia*.
- Prolong the life of the fence by preventing the steel (or other material) from sitting on the dirt and rusting.
- The UFP's available from *Outback Sleepers Australia* are designed to fit into a 50 x 50mm fence post.

1. Fence Posts.

- Install your fence posts as specified by the Fence panel manufacturer. **Note:** *Outback Sleepers Australia* recommends that the posts be extended and the hole dug a further 300mm deeper than the fence manufacturer's recommendation.

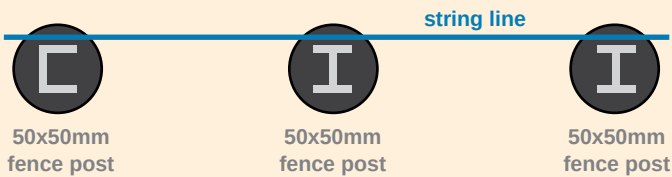

2. Remove Rail.

- Remove bottom fence rail.

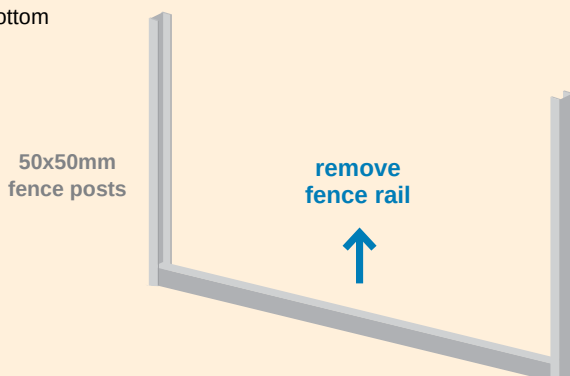

3. Concrete UFP.

- Insert concrete Under Fence Plinth in between posts.

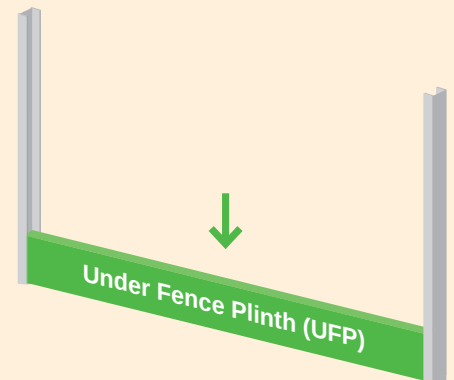

4. Replace Rail.

- Replace bottom rail, as per fence manufacturer's instructions.

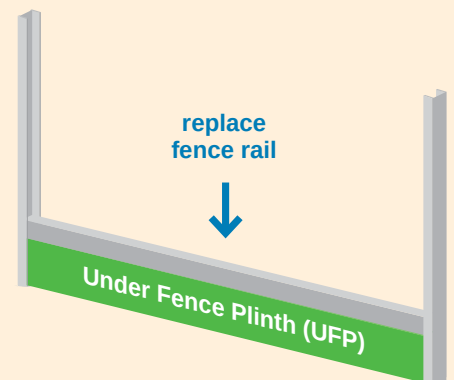

5. Fence Panel.

- Install fence panel, as per fence manufacturer's instructions.

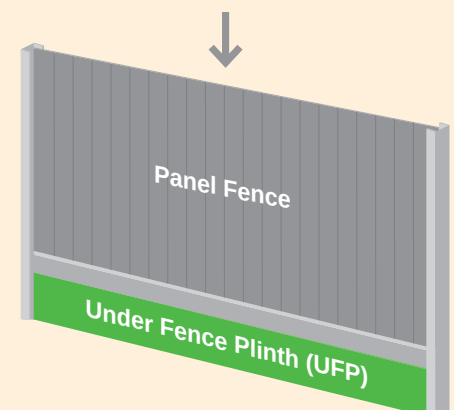

Installation Guide.

Step Kits



Before you begin, please read the tips below to ensure a smooth installation:

Tip #1: Set aside time to install – no-one wants a rushed job.

Tip #2: Only build one layer at a time.

Tip #3: IMPORTANT Do not add sides before placing tread and cribs on existing layers.

What you'll need:

- Sleepers (2 for each layer)
- Support Plates (2 for each layer)
- Locating Pins (2 for each layer)
- 10mm and 12mm Masonry bits
- Step Treads (2 for each layer)
- Cribs (1 for each layer)
- Masonry Drill
- Chemical Anchor Cartridge.

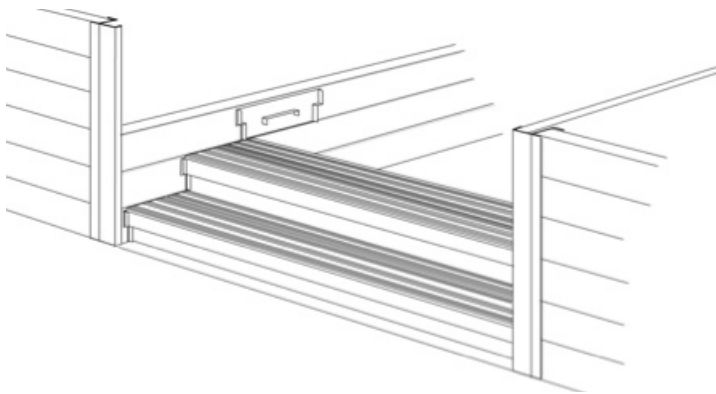

1. Steel Channels.

1. Mark out the width required between the front channels, this is determined by the width of the steps (see below):
 - a. 2.0m opening steps – set channels at 2010mm apart
 - b. 2.4m opening steps – set channels at 2410mm apart.
2. Mark the position of the rear holes at 2010mm centre to centre from the front holes.
3. Drill 450mm diameter holes for the columns at a depth equal to the height of the steps with a minimum depth 600mm.
4. Place channels into holes and prop them up checking that measurements are all correct and the channels are all square to each other, before pouring concrete into holes and allowing to set.



2. Support Plates.

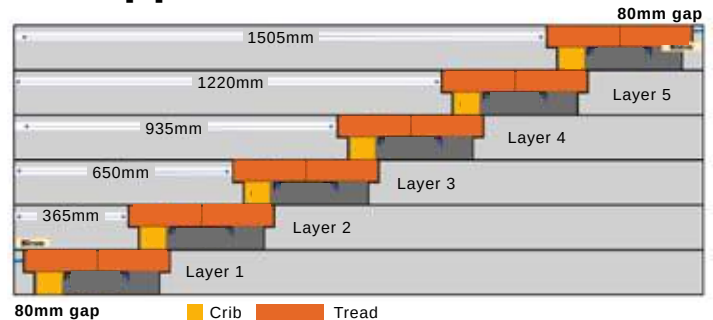

Bottom Step:

1. Place the first Support Plate centrally and squarely on the concrete sleeper, 80mm from the sleeper leading edge.
2. Drill two 10mm pilot holes into concrete sleeper, 20mm deep, through the holes in the Support Plate.
3. Remove the Support Plate and drill out the two holes to 12mm diameter, 60mm deep, into the sleeper. Clean out all dust and chips from the drilled holes before continuing. Using the Chemical Anchor cartridge recommended, inject approximately 2.5cc into each of the drilled holes. Within 5 minutes of application, push in the Locating Pins with a twisting motion (this eliminates any air bubbles) until they are firmly seated at the base of the hole. Wipe any excess anchoring material away.
4. Align the Support Plate over the Locating Pins.
5. Repeat the above process for the other side step sleepers; remembering to measure from the opposite end as the left side will be a mirror image of the right. Leave the sleeper for a minimum of 1 hour for the chemical anchor fluid to cure* before placement in the wall.

*Dependent on chemical anchor manufacturer's recommendations.

Subsequent Steps:

There are two methods for fixing the subsequent Step Brackets. Choose one from below:

- **Method One:** Line up the new sleeper with the Side Support Sleeper you have just made up; align the notch on the new sleeper with the back-edge of the Support Plate and continue from step 2. **OR**
- **Method Two:** Using a diagram, measure the distance from the front edge of the Side Support Sleeper to that of the step layer being laid; then continue from step 2.

3. Concrete Sleepers.

1. Starting from the bottom, place the first Side Sleeper on a smooth, solid surface between the Channel Piers. Repeat with the other side.
2. Place the Crib between the support brackets in the forward most opening.
3. Add two step treads onto the top section of the Support Plate, this will then complete the lowest step assembly.
4. Repeat this process with all following steps and backfill progressively.

Please call us on (08) 8387 9227 if you need any further assistance.

Further Information.



Delivery and Pick Up.

Transport

- Dedicated delivery vehicles.
- Forklift (Manitou) for site access.
- Kerbside delivery.
- Large Load capacity for commercial customers.

Loading Area

- Pick up available from Outback Sleepers Australia.
- Our loading areas can accommodate vehicles with trailers up to B-double trucks.

Please Note: We do not load cars, vans or cage trailers.

Concrete Sleepers. Important Information:

Specifications

Sleeper concrete grade is **60MPa**.

No heavy mechanical compaction within 75% height of wall.

These sleeper specifications are only suitable for use with retaining walls which satisfy the following conditions/limitations:

- The wall is not subject to heavy surcharge loads, for example; nearby existing retaining wall; structure; buildings within a distance equal to two times the wall height or placing a fence on the retaining wall.
- The final surface gradient above the wall is level or only slight (i.e less than 1 vertical rise in 10 horizontal).
- The wall backfill is free draining (consisting of sand and or gravel).
- All sub-surface water is drained by means of an agricultural drain or other suitable method.
- Sleepers minimum end bearing length shall not be less than 25mm each end.

Note: Please check with your local authority for specific regulations.

Sleeper engineering specification:

- **60 MPa**
- Concrete complies with AS3600/2018.
- Engineered and Certified.
- 50 Year Design Life-span.



We've used Outback Sleepers Australia for the last couple years because they manufacture the highest quality sleepers. We're a small-to-medium size retaining wall company in Adelaide, and they make ordering sleepers easy. They always deliver when they say they will, making our construction timeline predictable. On the very rare occasion a concrete sleeper is chipped or not 100% perfect, they bend over backwards and do everything they can to fix it right away. Their quality, service & ability to handle large orders in short time frames has enabled us to grow our company. – **Martin**

I have been using Outback Sleepers for my Retaining Walls and Under Fence Plinths now for about 2 years. The detail to there finished product is second to none, and there pricing is very competitive. I highly recommend giving Outback Sleepers a chance to quote next time you are thinking of Tendering your next Retaining Wall. – **Simon**

Outback Sleepers provide impeccable service and have not let us down on any occasion. The wide range of quality products makes it extremely easy to meet project engineering requirements. I have also found their delivery service to be very reliable and professional. – **Mitchell**



**OUTBACK
SLEEPERS
AUSTRALIA**

Adding distinction to your landscape design

Contact Us.

17 Lindsay Road,
Lonsdale SA 5160

T: (08) 8387 9227

F: (08) 8387 8824

sales@outbacksleepers.com.au

www.outbacksleepers.com.au

